

Power Server Module

NOW WITH A 10-YEAR WARRANTY!

Nextek's PSM: The Heart of Your Direct Current System

FEATURES

- Easy conversion of AC lighting fixtures to DC-powered systems.
- Easy conversion of AC grid power into DC power for commercial building applications.
- Converts 120, 208, 240 and 277 VAC, or 380 VDC, to 24 VDC through 16 individual Class 2 outputs.
- Wireless, fully programmable control and monitoring through our SKY Controls equipment and software.
- Safe2Touch, low-voltage DC distribution that allows quick plug-and-play, energy efficient and individually controllable DC lighting and other loads.
- 16 different PSM models to fit every location's needs.
- Each channel is protected by redundant current and voltage sensors and shutdown in case of channel load exceeds 100VA.
- Patented triangular design mounts directly on a suspended ceiling grid for ease of installation.
- Modular component design means easy reconfiguration of lighting layout.
- 208VAC models are compatible with DIRTT Environmental Solutions Power Feed connector model MW01-45W.

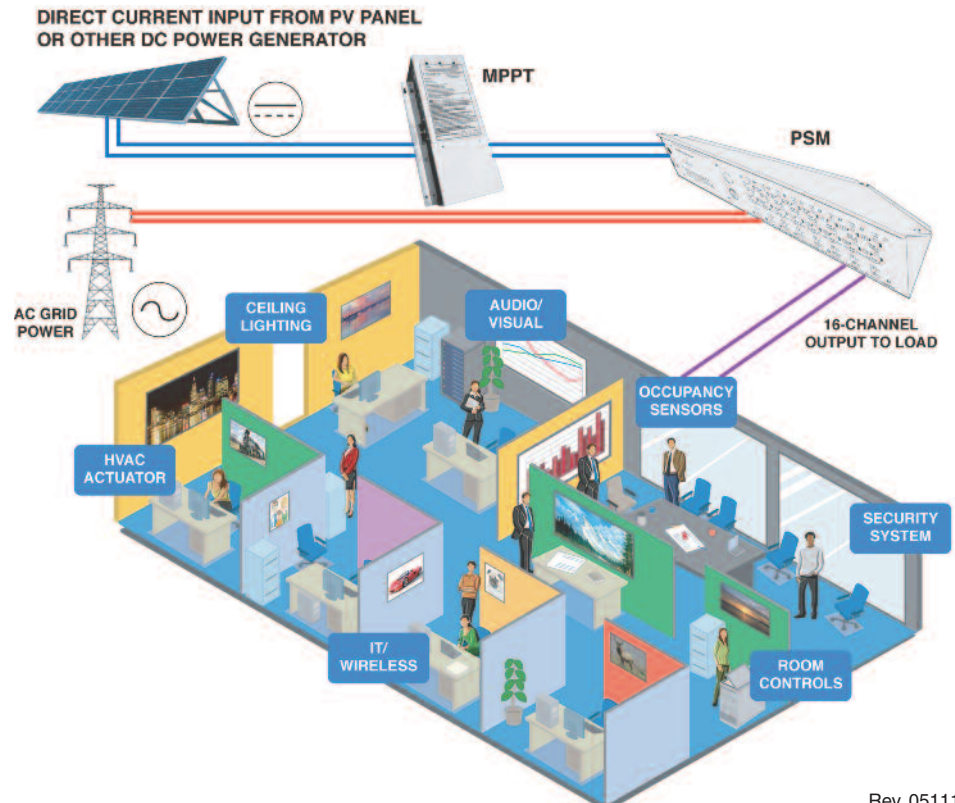

For more information:

Nextek Power Systems
461 Burroughs Street
Detroit, Michigan 48202
www.nextekpower.com

Tel: 313-887-1321
Toll free: 1 (877) 24-VOLTS
Fax: 313-887-9433
info@nextekpower.com



Rev. 051114

PSM Technical Specifications

COMPLIANCE / FILE NO.

- UL 1012/1310: E329770
- UL 2043: SV18048
- UL 2577: E337393
- EmergeAlliance® Registered
- RoHS compliant

MECHANICAL	ALL MODELS
Dimensions	see diagram below
Weight	21.0 - 26.0 lbs.
Mounting Orientation	Flat horizontal surface – using rubber feet Ceiling grid – using plastic grid interconnects, or however you can safely mount it
Audible Noise	Less than 15 dBA
Operational Environmental Limits	Temperature Range: 0° to 49°C Humidity: 90% RH non-condensing Vibration: Low-Frequency 10-55 Hz
Storage Environmental Limits	Temperature Range: -40° to 60°C Humidity: 95% RH non-condensing (transport and storage in protective container) Vibration: Low-Frequency 10-55 Hz
Construction	Made of 20 gauge steel, manufactured in U.S.A.
Installation	When installed in a suspended ceiling, installation requires a minimum of 8" from the top of the ceiling grid to the deck.

NOMENCLATURE

PSM	–	XXXX	–	C2	–	XXX	–	X	–	XXX
1 PSM: Power Server Module		2 Power Rating 950: 950W 1600: 1600W		3 C2: Class 2 Output		4 120: 120VAC input 380: 330-400 VDC input 380H: 380-430 VDC input R1: 208-240 VAC input		5 Z: ZigBee or 6: 6LoWPan		6 ALT: Additional 24VDC Input using optional MPPT

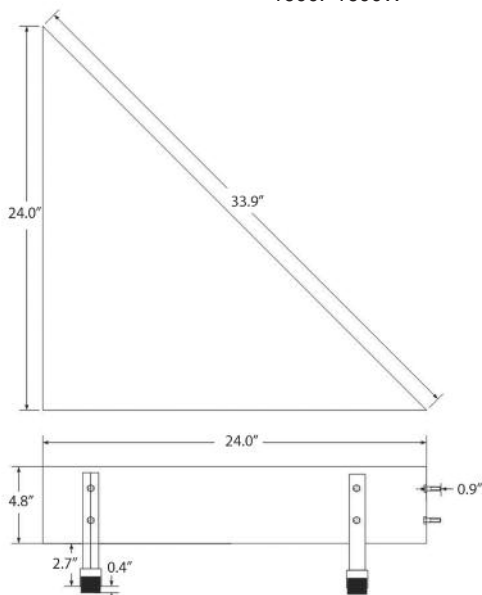

FCC Requirements:

This device complies with Part 15 of the FCC rules. Operation is subject to the following two conditions: (1) This device may not cause harmful interference, and (2) this device must accept any interference received, including interference that may cause undesired operation.

Changes or modifications not expressly approved by Nextek Power Systems, Inc. for compliance could void the user's authority to operate the equipment.

Note:

This equipment has been tested and found to comply with the limits for a Class A or Class B digital device, pursuant to Part 15 of the FCC rules. These limits are designed to provide reasonable protection against harmful interference in a residential installation. This equipment generates, uses, and can radiate radio frequency energy and, if not installed and used in accordance with the instruction manual, may cause harmful interference to radio communication. However, there is no guarantee that interference will not occur in a particular installation. If this equipment does cause harmful interference to radio or television reception, which can be determined by turning the equipment on and off, the user is encouraged to try to correct the interference by one or more of the following measures:

- Reorient or relocate the receiving antenna.
- Increase the separation between the equipment and receiver.
- Connect the equipment into an outlet on a circuit different from that to which the receiver is connected.
- Consult the dealer or an experienced radio/TV technician for help.

Rev. 051114

PSM Technical Specifications

ELECTRICAL

PSM MODELS:	Input Power	ALT-E Input Pwr	Output Per Channel	Efficiency	Wireless
PSM-1600-C2-Z	170-305 VAC sgl phase, 13.5 A max. 50/60 HZ	n/a		94.3% @ 277 VAC input	ZigBee®
PSM-1600-C2-6					6LoWPan
PSM-1600-C2-Z-ALT		24.0 – 24.5 VDC, 65 A max @ 99.8% efficiency			ZigBee®
PSM-1600-C2-6-ALT					6LoWPan
PSM-1600-C2-380-Z PSM-1600-C2-380H-Z	380: 330-400 VDC 380H: 380-430 VDC	n/a	24 VDC ± 3% 95 W maximum current limited to 3.96 A continuous Rated impulse current: 80 A for .2 mSec	96.3% @ 380 VDC input (350-390)	ZigBee®
PSM-1600-C2-380-6 PSM-1600-C2-380H-6					6LoWPan
PSM-1600-C2-380-Z-ALT PSM-1600-C2-380H-Z-ALT		24.0 – 24.5 VDC, 65 A max @ 99.8% efficiency			ZigBee®
PSM-1600-C2-380-6-ALT PSM-1600-C2-380H-6-ALT					6LoWPan
PSM-1600-C2-R1-Z	154-270 VAC sgl phase, 13.5 A max. 50/60 HZ	n/a		90% @ 240 VAC input	ZigBee®
PSM-1600-C2-R1-6					6LoWPan
PSM-1600-C2-R1-Z-ALT		24.0 – 24.5 VDC, 65 A max @ 99.8% efficiency			ZigBee®
PSM-1600-C2-R1-6-ALT					6LoWPan
PSM-950-C2-120-Z	88-154 VAC sgl phase, 9.5 A max. 50/60 HZ	n/a	24 VDC ± 3%, 59 W maximum current limited to 2.47 A continuous. Rated impulse current – 80 A for .2 mSec	88% @ 120 VAC input	ZigBee®
PSM-950-C2-120-6					6LoWPan
PSM-950-C2-120-Z-ALT		24.0 – 24.5 VDC, 65 A max @ 99.8% efficiency			ZigBee®
PSM-950-C2-120-6-ALT					6LoWPan

Systems Faults: Overvoltage, Undervoltage and Overtemperature automatically reset when the problem clears.

Channels each have status readable through wireless software:

- Disabled: Channel has been disabled (by double-clicking)
- Inrush: PSM has detected a startup-load inrush on a channel and is trying to rapidly turn the channel on and off until current is less than 4 Amps
- VoutLow: The positive channel output voltage is less than 18V.
- Imatch: Positive and negative channel current measurements differ by more than 1.5 Amps
- Parallel: PSM detected interconnected (paralleled) channel wiring on startup test.
- Shorted: PSM detected a short-circuit in channel wiring.

PSM Technical Specifications

Which PSM is for You?

New models of the Power Server Module have a variety of features that give users greater control and flexibility. See the chart on page 3 to determine which models are considered standard or new.

PSM FEATURES	STD MODELS	NEW MODELS
	PSM 2.5	NPS PSM 3.0
120 VAC	✓	n/a
208 VAC Compatible with DIRTT Environmental Solutions Power Feed Cable, part # MW01-45W (208 VAC only)	✓	✓
240 VAC	✓	✓
277 VAC	✓*	✓
380 VDC	n/a	✓
FCC A	✓	✓
FCC B	✓	n/a
16 channels	✓	✓
Enclosure Height (inches)	4.5	5.1
Efficiency AC	90%	94%
Efficiency 380 VDC	n/a	96.50%
ZigBee®	✓	✓
6LoWPan	n/a	✓
Amatis Controls compatibility	n/a	✓
Weight (lbs.)	21	26
Fan Cooling	On at start	On after 800 W
Quiescent AC Power (W)	17.5	13.8
Quiescent DC Power (W)	n/a	12.5
Quiescent Solar Power (W) (24V Aux input only)	7	5
AC I/O Ports**	2	1
DC I/O Ports**	2	1
*Using the Nextek Auto Transformer		
**Holes in the housing allow for daisy chaining of AC or DC from one PSM to another.		

Rev. 051114

While Nextek Power Systems has made every reasonable effort to ensure the accuracy of the information in this catalog, Nextek Power Systems does not guarantee that it is error free, nor do they make any other representation, warranty or guarantee that the information is accurate, correct, reliable or current. Nextek Power Systems, Inc. reserves the right to make any adjustments to the information contained herein at any time without notice. The specifications in this catalog are for reference purposes only and are subject to change without notice. Consult Nextek Power Systems for the latest design specifications. All trademarks are either the exclusive property of Nextek Power Systems, Inc. or other companies. Copyright 2013-2014 by Nextek Power Systems, Inc. in the United States and other countries throughout the world.