



Quick Payback, Quality Illumination: What Simple LED Lamp Refits Can Do for You

Adoption of LED lighting is undeniably on the rise—we are experiencing its benefits in our homes, workplaces, stores and cities. The reason for this shift is clear: LEDs bring new levels of energy efficiency and longevity, minimizing costs.

While most people see the value in LED lighting technology, some have been hesitant to commit to installing new LED fixtures, settling for less-efficient options instead. What they may not know, however, is that there is another option. While LED fixtures deliver a strong ROI over time, decision makers can also find quick payback and quality illumination with easy-to-install LED retrofit solutions.



Rethinking the Dominance of LFL

LED retrofit solutions allow easy installation of long-lasting, energy-efficient lighting without major fixture changes through simple one-to-one lamp exchanges. Think fluorescent lamps are the only practical option for ambient commercial lighting? Think again.

Billions of linear fluorescent lighting (LFL) tubes exist in warehouses, retail facilities, offices and other large commercial spaces worldwide. They surround us daily, and for decades we have considered fluorescent lighting a relatively efficient technology. Thanks to LEDs, that perception is now shifting.

LFL may be ubiquitous, but it has been optimized about as much as it can be. Trust us, we know—GE has produced LFLs since the 1930s and has helped advance the technology for decades. LFL is also seen by some as overly “harsh” due to the high color temperature and lower CRI often used and the frequency of over-lighting in many environments that use LFL.

Now there is a better option. LED tube lamps can serve as direct replacements for LFL, enabling greater efficiency, longevity and a better quality of light with little installation effort required.

Why Choose LED Tubes?

There are a variety of reasons to replace LFLs with LEDs, including:

66%
longer rated lifetimes
than LFLs, meaning
**less disruption
& relamping costs**

As much as
43–53%
less energy
required to operate
than LFL alternatives*

Better lighting quality
with instant full brightness,
warm and cool
color temperatures,
numerous lumen options
and higher CRI (80+)

Improved durability
& hassle-free disposal
with NSF-rated
shatter-resistant
tube options and
no hazardous materials

Which LED Tube Type Is Right for You?

If LED tubes sound compelling, the first thing to think about is which type best suits your needs. The right choice depends on whether you want the easiest installation or the highest efficiency.

- **UL Type A tubes with integrated drivers utilize existing LFL ballasts;** no wiring or tools are required. Perform a simple swap of the existing LFL with a UL Type A LED tube, and you are done. Lifespan and compatibility of UL Type A tubes depend on the existing LFL ballast, and dimming capabilities are limited on these models—but installation could not be easier.
- **UL Type C tubes require installation of a remote driver and removal of the existing LFL ballast,** meaning they take more effort to install than Type A, but far less than putting in a new fixture. UL Type C offers the highest system efficacy, compatibility and performance, however, and it allows robust dimming and control functionality.

How Much Could You Benefit?

Wondering whether LED tubes are right for your business? Consider the following factors to determine the opportunity for improvement for your building:

What sort of LFL tubes are you considering replacing?

Energy savings will vary based on existing technology: A T12 LFL lamp is less efficient than a T8 or T5, and ballasts affect energy consumption, too.

Where do you want LED tubes?

Lamp alternatives are available for 2-, 3-, 4- and 8-foot LFL tube applications, as well as U-tubes and high-lumen applications. T5 LED replacement options will be coming soon.

How much cost/disruption can be avoided with less frequent tube light replacement?

Especially in hard-to-access or high-traffic areas, decreased maintenance could make a big difference.

How would better quality of light be beneficial?

Employees or customers may prefer a different level of light output, warmer color temperature, better color rendering or instant brightness.

Savings from switching to LED tubes adds up fast.

Consider the case of one of the nation's largest apparel, cosmetics and home furnishings retailers. Seeking less maintenance, lower energy costs and the ability to sync LED tube fixtures with new lighting controls, this company relamped 50,000 fixtures across 44 stores in 2015, unlocking \$544,500 in savings. In 2016, the retailer plans to convert another 74,000 fixtures, bringing annual savings to more than \$1.3 million. All told, the company stands to reduce its lighting spend by as much as \$15 million over the rated life of GE's LED tube product purely from energy savings gained from switching from LFL to LED lamps.



In 2015, a major retailer relamped

50,000

FIXTURES ACROSS

44 STORES

SAVING

\$544,500

LED Tubes At-A-Glance



Designed to fit in fixtures intended for linear fluorescent lamps (LFLs), LED tubes from GE are a smart, efficient and long-lasting solution to replace traditional lighting.

GE Lighting offers two solutions. To ensure the lamp you choose is the best for your application and to help your decision be easier and more informed, here is a quick rundown of those choices.

GE Recommends - Easiest Installation	Not Recommended	GE Recommends - Best Performance
UL TYPE A	UL TYPE B	UL TYPE C
LED Tube with Integrated Driver Wired to Existing LFL Ballast	LED Tube with Integrated Driver Wired to Mains	LED Tube with Remote Driver
<ul style="list-style-type: none"> Delivers lowest installation cost. No rewiring required for installation Limited dimming capabilities Reduced system efficacy System compatibility dependent upon LFL ballast Life dependent on LED tube and LFL ballast 	<ul style="list-style-type: none"> Medium installation cost. Requires rewiring for installation Limited dimming capabilities Higher system efficacy than UL Type A Good system compatibility between LED tube and driver Additional safety processes required due to high-voltage wires 	<ul style="list-style-type: none"> Medium installation cost. Requires rewiring for installation Controllable dimming system Best system efficacy Optimal system compatibility between GE LED tube and GE Lighttech driver Low-voltage connection to sockets minimizes shock hazard
GE LIGHTING'S SOLUTION		GE LIGHTING'S SOLUTION
LED Tube with integrated Lighttech™ driver	<i>GE does not anticipate that it will offer UL Type B tubes in North America.</i>	LED Tube with remote Lighttech™ driver

Two icons (above) represent Best-In-Class feature

Note: UL Type B solutions require changing the lamp holder.

To learn more about the best lighting solution for your needs, visit www.gelighting.com/refitsolutions or schedule a free lighting audit from GE today!



www.gelighting.com

GE and the GE Monogram are trademarks of the General Electric Company. Information provided is subject to change without notice. All values are design or typical values when measured under laboratory conditions. © 2014 GE Lighting.

14688-GB (Rev 8/8/16)

Refit Solutions from GE



Application illustration only, subject lamps not used in photo.

Type C LED Tubes - 2, 3 and 4 foot

Convert your existing linear fluorescent fixture to LED lighting without needing a comprehensive reinstall. LED tubes are ideal for those seeking high energy savings with minimal installation time. Each LED tube is operated by a GE Lightech™ driver. See reverse for LED tubes and Lightech driver product details.

FEATURES

- 2', 3' & 4' tubes
- 900 – 2,200 lumens
- >100 total system lumens per watt (LPW)
- 3000K, 3500K, 4000K, 5000K and 6500K color temperatures
- 50,000-hour rated life
- UL and CUL-approved technologies
 - in compliance with UL 1598 certification
- Open or Enclosed Fixtures
- NSF Rated for food application (shatter resistant)
- Damp rating
- 5 year warranty
- DLC listed

BENEFITS

- Fast and Easy LED upgrade
- Low energy LFL replacement
- 66% longer life than LFL (50,000 vs. 30,000 hours)
- Better quality of light
 - instant on
- Shatter resistant
 - prevents breakage and downtime
- Easy disposal, non-hazardous waste

To learn more about saving money and energy, go to: gelighting.com/ThinkLED

When you Think LED lighting, Think GE.

ecomaginationSM



imagination at work

Information provided is subject to change without notice. Please verify all details with GE. All values are design or typical values when measured under laboratory conditions, and GE makes no warranty or guarantee, expressed or implied, that such performance will be obtained under end-use conditions.

Product Specifications - 2-3-4 Foot LED Tubes

Refit LED Tubes

Type	Base Type	Watts	Order Code	Description	Volts	Case Qty**	MOL (in)	Lumens Initial	Initial Color Temp	CRI	Wattage Replacement	*Rated Life L70 (Hrs)	DLC	UL	#Location Rating	Additional Information
Remote Plastic 4 ft LED Tubes (Operates on Remote Driver)																
T8	G13	18	94381	LED21T8/4/835		10	48	2400	3500K	80+		50,000	Yes	Yes	Damp	Requires Driver
	G13	18	94382	LED21T8/4/840		10	48	2500	4000K	80+		50,000	Yes	Yes	Damp	Requires Driver
	G13	18	94383	LED21T8/4/850		10	48	2500	5000K	80+		50,000	Yes	Yes	Damp	Requires Driver
	G13	18	26059	LED21T8/4/865		10	48	2400	6500K	80+		50,000	-	Yes	Damp	Requires Driver
	G13	13	38954	LED15T8/4/830		10	48	1700	3000K	80+		50,000	Yes	Yes	Damp	Requires Driver
	G13	13	38957	LED15T8/4/835		10	48	1800	3500K	80+		50,000	Yes	Yes	Damp	Requires Driver
	G13	13	38958	LED15T8/4/840		10	48	1800	4000K	80+		50,000	Yes	Yes	Damp	Requires Driver
	G13	13	38962	LED15T8/4/850		10	48	1800	5000K	80+		50,000	Yes	Yes	Damp	Requires Driver
	G13	13	38964	LED15T8/4/865		10	48	1800	6500K	80+		50,000	-	Yes	Damp	Requires Driver
Remote Plastic 3 ft LED Tubes (Operates on Remote Driver)																
	G13	16	82343	LED18T8/3/835		10	36	1800	3500K	80+		50,000	-	Yes	Damp	Requires Driver
	G13	16	82345	LED18T8/3/840		10	36	1800	4000K	80+		50,000	-	Yes	Damp	Requires Driver
	G13	16	82346	LED18T8/3/850		10	36	1800	5000K	80+		50,000	-	Yes	Damp	Requires Driver
Remote Plastic 2 ft LED Tubes (Operates on Remote Driver)																
	G13	8	65706	LED9T8/2/835		20	24	1000	3500K	80+		50,000	Yes	Yes	Damp	Requires Driver
	G13	8	65707	LED9T8/2/840		20	24	1100	4000K	80+		50,000	Yes	Yes	Damp	Requires Driver
	G13	8	65711	LED9T8/2/850		20	24	1100	5000K	80+		50,000	Yes	Yes	Damp	Requires Driver
	G13	8	92997	LED9T8/2/865		20	24	1000	6500K	80+		50,000	-	Yes	Damp	Requires Driver

Lightech Drivers - Non Dimming

GE Product Code	Description	# of Lamps
93100	LED9T8/DR/UN/2L	2
76289	LED12T8/DR/2L	2
38970	LED15T8/DR/UN/2L	2
82347	LED18T8/DR/UN/2L	2
94384	LED21T8/DR/1L	1
94385	LED21T8/DR/2L	2

Lightech Drivers - Dimming

GE Product Code	Description	# of Lamps
76290	LED12T8/DR/D2L	2
76318	LED12T8/DR/4DL	4
38974	LED15T8/DR/D2L	2
38975	LED15T8/DR/4DL	4
88141	LED18T8/DR/D2L	2
88139	LED18T8/DR/4DL	4
60041	LED21T8/DR/D/2L	2
34016	LED21T8/DR/VLC/2L	2
62030	LED21T8/DR/D/4L	4

General Characteristics - Non Dimming

GE Product Code	76289	38970	82347	94384	94385
Output Current (A)	0.21*2	0.44*2	0.53*2	0.62	0.62*2
Input Watt (Max)	24	30	36	21	42
Input Voltage (V)	120-277V				
Input Frequency (Hz)	50/60Hz				
Efficiency (%)	> .9%				
Output Type	DC				
Output Volt Range	26-34V				
Dimmability	None				
Ambient Temp Min	-4°F				
Ambient Temp Max	113°F				
Case Temperature	158°F				

General Characteristics - Dimming

GE Product Code	88141	76290	38974	60041	34016	38975	62030	76318	88139
Output Current (A)	0.53*2	0.21*2	0.44*2	0.62*2	0.62*2	0.44*4	0.62*4	0.21*4	0.53*4
Input Watt (Max)	36	24	30	42	42	60	84	48	72
Input Voltage (V)	120-277V								
Input Frequency (Hz)	50/60Hz								
Efficiency (%)	> .9%								
Output Type	DC								
Output Volt Range	26-34V								
Dimmability	0-10V								
Ambient Temp Min	-4°F								
Ambient Temp Max	113°F								
Case Temperature	158°F								

Dimensions - Non Dimming

GE Product Code	82347	76289	38970	94384	94385
Weight	1.01	1.01	1.01	1.01	1.01
Casing Length (in)	9.5				
Casing Width (in)	1.3				
Casing Height (in)	1				
Lead Exit Length (in)	26				
Input Wire Length (in)	36				
Output Wire Length (in)	38				

Dimensions - Dimming

GE Product Code	76290	38974	34016	60041	38975	62030	76318
Weight	1.01			1.08			
Casing Length (in)	9.5						
Casing Width (in)	1.3						
Casing Height (in)	1						
Lead Exit Length (in)	26						
Input Wire Length (in)	36						
Output Wire Length (in)	38						



Product is compliant with material restriction requirements of RoHS



www.gelighting.com

GE and the GE Monogram are trademarks of the General Electric Company. All other trademarks are the property of their respective owners. Information provided is subject to change without notice. All values are design or typical values when measured under laboratory conditions. GE Lighting and GE Lighting Solutions, LLC are businesses of the General Electric Company. © 2016 GE.

LEDL016 (Rev 10/27/16)

Refit Solutions from GE



Application illustration only, subject lamps not used in photo.

Type C LED Tubes - assembled in USA

Convert your existing linear fluorescent fixture to LED lighting without needing a comprehensive reinstall. LED tubes are ideal for those seeking high energy savings with minimal installation time. Each LED tube is operated by a GE Lightech™ driver. See reverse for LED tubes and Lightech driver product details.

FEATURES

- 4' and 8' glass tubes
- 2600-4400 lumen options available
- >120 total system lumens per watt (LPW)
- 3000K, 3500K, 4000K and 5000K color temperatures
- 50,000-hour rated life
- UL and CUL listed
 - in compliance with UL 1598 certification
- Open or Enclosed Fixtures
- Damp rating
- 5 year warranty

BENEFITS

- Fast and easy LED upgrade
- Low energy LFL replacement
- 66% longer life than LFL (50,000 vs. 30,000 hours)
- Better quality of light – instant on
- Fully illuminates fixture
 - 270° light distribution
- Easy disposal, non-hazardous waste
- State-of-Art USA Assembly
 - Perfect for special projects

To learn more about saving money and energy, go to: gelighting.com/ThinkLED

When you Think LED lighting, Think GE.

ecomaginationSM



imagination at work

Information provided is subject to change without notice. Please verify all details with GE. All values are design or typical values when measured under laboratory conditions, and GE makes no warranty or guarantee, expressed or implied, that such performance will be obtained under end-use conditions.

Product Specifications

Refit LED Tubes

GE Product Code	Description	Bulb Shape	Base	Tube Watts	Case Quantity	Length (In)	Initial Lumens	Color Temp (K°)	CRI	*Rated Life L70 (Hrs)
4ft LED Tubes										
91475	LED21T8/G4/830US	T8	Medium Bi-Pin (G13)	18	20	48"	2600	3000	+80	50,000
91496	LED21T8/G4/835US	T8	Medium Bi-Pin (G13)	18	20	48"	2600	3500	+80	50,000
91497	LED21T8/G4/840US	T8	Medium Bi-Pin (G13)	18	20	48"	2600	4000	+80	50,000
91498	LED21T8/G4/850US	T8	Medium Bi-Pin (G13)	18	20	48"	2600	5000	+80	50,000
8ft LED Tubes										
62326	LED36T8/G/8/830	T8	Single Pin (Fa8)	30	20	96"	4200	3000	+80	50,000
62327	LED36T8/G/8/835	T8	Single Pin (Fa8)	30	20	96"	4400	3500	+80	50,000
62329	LED36T8/G/8/840	T8	Single Pin (Fa8)	30	20	96"	4400	4000	+80	50,000
62349	LED36T8/G/8/850	T8	Single Pin (Fa8)	30	20	96"	4400	5000	+80	50,000

Lightech Drivers - Non Dimming

GE Product Code	Description	# of Lamps
94384	LED21T8/DR/1L	1
94385	LED21T8/DR/2L	2

Lightech Drivers - Dimming

GE Product Code	Description	# of Lamps
60041	LED21T8/DR/D/2L	2
34016	LED21T8/DR/VLC/2L	2
62030	LED21T8/DR/D/4L	4
63126	LED36T8/DR/D2L	2

General Characteristics - Non Dimming

GE Product Code	94384	94385
Output Current (A)	0.62	0.62*2
Input Watt (Max)	21	42
Input Voltage (V)	120-277V	
Input Frequency (Hz)	50/60Hz	
Efficiency (%)	> .9%	
Output Type	DC	
Output Volt Range	27-33V	
Dimmability	None	
Ambient Temp Min	-4°F	
Ambient Temp Max	104°F	
Case Temperature	158°F	

General Characteristics - Dimming

GE Product Code	60041	34016	62030	63126
Output Current (A)	0.62*2	0.62*2	0.62*4	0.54*2
Input Watt (Max)	42	42	84	72 (36 x 2)
Input Voltage (V)	120-277V			
Input Frequency (Hz)	50/60Hz			
Efficiency (%)	> .9%			
Output Type	DC			
Output Volt Range	27-33V		26-34V	
Dimmability	0-10V		0-10V	
Ambient Temp Min	-4°F		-4°F	
Ambient Temp Max	104°F		113°F	
Case Temperature	158°F		158°F	

Dimensions - Non Dimming

GE Product Code	94384	94385
Weight	1.01	1.08
Casing Length (in)	9.5	
Casing Width (in)	1.3	
Casing Height (in)	1	
Lead Exit Length (in)	26	
Input Wire Length (in)	36	
Output Wire Length (in)	38	

Dimensions - Dimming

GE Product Code	60041	34016	62030	63126
Weight	1.01	1.08	1.08	1.01
Casing Length (in)	9.5	9.5	9.5	9.5
Casing Width (in)	1.3	1.7	1.3	1.3
Casing Height (in)	1	1	1	1
Lead Exit Length (in)	26	26	26	26
Input Wire Length (in)	36	36	36	36
Output Wire Length (in)	38	42	42	38

ecomaginationSM



Product is compliant with material restriction requirements of RoHS



www.gelighting.com

GE and the GE Monogram are trademarks of the General Electric Company. All other trademarks are the property of their respective owners. Information provided is subject to change without notice. All values are design or typical values when measured under laboratory conditions. GE Lighting and GE Lighting Solutions, LLC are businesses of the General Electric Company. © 2016 GE.

LEDL035 (Rev 12/07/16)

Refit Solutions from GE



Application illustration only, subject lamps not used in photo.

Type C LED U-Tube

Convert your existing linear fluorescent fixture to LED lighting without needing a comprehensive reinstall. LED tubes are ideal for those seeking high energy savings with minimal installation time. Each LED tube is operated by a GE Lightech™ driver. See reverse for LED tubes and Lightech driver product details.

FEATURES

- T8 U-Tube 1-5/8" and 6" Spacing
- 1700-1800 lumen option available
- >120 total system lumens per watt (LPW)
- 3000K, 3500K, 4000K and 5000K
- 50,000-hour rated life
- UL and cUL listed
 - in compliance with UL 1598 certification
- NSF Rated for food applications (1-5/8" only)
- Open or Enclosed Fixtures
- Damp rating
- Dimmable (0-10V)
- 5 year warranty

BENEFITS

- Fast and Easy LED upgrade
- Low energy LFL replacement
- 2X longer life than LFL (50,000 vs. 24,000 hours)
- Better quality of light
 - instant on
- No UV
- Shatter resistant (1-5/8" only)
 - prevents breakage and downtime
- Easy disposal, non-hazardous waste

To learn more about saving money and energy, go to: gelighting.com/ThinkLED

When you Think LED lighting, Think GE.

ecomaginationSM



imagination at work

Information provided is subject to change without notice. Please verify all details with GE. All values are design or typical values when measured under laboratory conditions, and GE makes no warranty or guarantee, expressed or implied, that such performance will be obtained under end-use conditions.

Product Specifications

Refit LED Tubes

GE Product Code	Description	Bulb Shape	Base	Watts	Case Quantity	Length (In)	Initial Lumens	Color Temp (K°)	CRI	*Rated Life L70 (Hrs)
Type C LED U-Tube										
28084	LED14T8/U/835	T8	Med Bi-Pin (G13)	12	15	22.5"	1700	3500	80	50,000
28164	LED14T8/U/840	T8	Med Bi-Pin (G13)	12	15	22.5"	1700	4000	80	50,000
43131	LED15T8/G/U6/830	T8	Med Bi-Pin (G13)	13	12	22.5"	1700	3000	80	50,000
43135	LED15T8/G/U6/835	T8	Med Bi-Pin (G13)	13	12	22.5"	1800	3500	80	50,000
43143	LED15T8/G/U6/840	T8	Med Bi-Pin (G13)	13	12	22.5"	1800	4000	80	50,000
43145	LED15T8/G/U6/850	T8	Med Bi-Pin (G13)	13	12	22.5"	1850	5000	80	50,000

Lightech™ Drivers - Dimming (for 1-5/8")

GE Product Code	Description	# of Lamps
28174	LED14T8/DR/D3L	3

General Characteristics

GE Product Code	28174
Output Current (A)	0.43*3
Input Watt (Max)	43
Input Voltage (V)	120-277V
Input Frequency (Hz)	50/60Hz
Efficiency (%)	> .9%
Output Type	DC
Output Volt Range	26-34V
Dimmability	0-10V
Ambient Temp Min	-4°F
Ambient Temp Max	113°F
Case Temperature	158°F
Driver Rating	>50,000 hours
Casing Length (in)	9.5
Casing Width (in)	1.3
Casing Height (in)	1
Lead Exit Length (in)	26
Input Wire Length (in)	36
Output Wire Length (in)	38

Lightech™ Drivers - Non-Dimming (for 6")

GE Product Code	Description	# of Lamps
38970	LED15T8/DR/UN/2L	2

General Characteristics

GE Product Code	38970
Output Current (A)	0.44*2
Input Watt (Max)	30
Input Voltage (V)	120-277V
Input Frequency (Hz)	50/60Hz
Efficiency (%)	> .9%
Output Type	DC
Output Volt Range	26-34V
Dimmability	None
Ambient Temp Min	-4°F
Ambient Temp Max	113°F
Case Temperature	158°F
Driver Rating	>50,000 hours
Casing Length (in)	9.5
Casing Width (in)	1.3
Casing Height (in)	1
Lead Exit Length (in)	26
Input Wire Length (in)	36
Output Wire Length (in)	38

Lightech™ Drivers - Dimming (for 6")

GE Product Code	Description	# of Lamps
38974	LED15T8/DR/D2L	2

General Characteristics

GE Product Code	38974
Output Current (A)	0.44*2
Input Watt (Max)	30
Input Voltage (V)	120-277V
Input Frequency (Hz)	50/60Hz
Efficiency (%)	> .9%
Output Type	DC
Output Volt Range	26-34V
Dimmability	0-10V
Ambient Temp Min	-4°F
Ambient Temp Max	113°F
Case Temperature	158°F
Driver Rating	>50,000 hours
Casing Length (in)	9.5
Casing Width (in)	1.3
Casing Height (in)	1
Lead Exit Length (in)	26
Input Wire Length (in)	36
Output Wire Length (in)	38

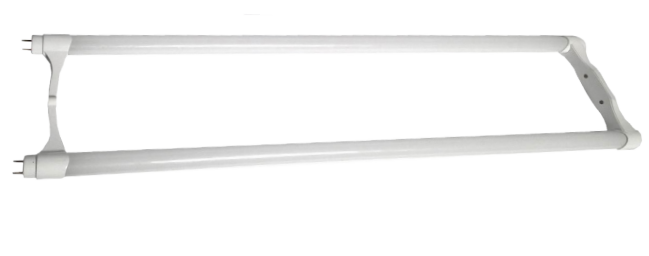

ecomaginationSM



Product is compliant with material restriction requirements of RoHS



www.gelighting.com

GE and the GE Monogram are trademarks of the General Electric Company. All other trademarks are the property of their respective owners. Information provided is subject to change without notice. All values are design or typical values when measured under laboratory conditions. GE Lighting and GE Lighting Solutions, LLC are businesses of the General Electric Company. © 2016 GE.

LEDL023 (Rev 1/19/17)

Refit Solutions from GE



Application illustration only, subject lamps not used in photo.

Type C LED Tubes - Glass

Convert your existing linear fluorescent fixture to LED lighting without needing a comprehensive reinstall. LED tubes are ideal for those seeking high energy savings with minimal installation time. Each LED tube is operated by a GE Lightech™ driver. See reverse for LED tubes and Lightech driver product details.

FEATURES

- 2'-4' glass tubes
- 1,000 -2,300 lumen options available
- > 270° beam spread
- > 105 total system lumens per watt (LPW)
- 3000K, 3500K, 4000K, 5000K and 6500K color temperature
- 50,000-hour rated life
- Open or enclosed fixtures
- 5 year warranty
- UL and CUL- approved technologies
 - in compliance with UL 1598 certification
- DLC Listed (2' and 4')

BENEFITS

- Fast and Easy LED upgrade
- Low energy LFL replacement
- 66% longer life than LFL (50,000 vs. 30,000 hours)
- Better quality of light
 - instant on
- Fully illuminates fixture
 - >270° light distribution
- Easy disposal, non-hazardous waste

To learn more about saving money and energy, go to: gelighting.com/ThinkLED

When you Think LED lighting, Think GE.

ecomaginationSM



imagination at work

Information provided is subject to change without notice. Please verify all details with GE. All values are design or typical values when measured under laboratory conditions, and GE makes no warranty or guarantee, expressed or implied, that such performance will be obtained under end-use conditions.

Product Specifications

GE Product Code	Description	Bulb Shape	Base	Watts	Case Quantity	Length (In)	Initial Lumens	Color Temp (K°)	CRI	*Rated Life L70 (Hrs)	DLC
2ft LED Tube											
38933	LED9T8/G/2/830	T8	Med Bi-Pin (G13)	8	20	24"	1000	3000	80+	50,000	Yes
38935	LED9T8/G/2/835	T8	Med Bi-Pin (G13)	8	20	24"	1100	3500	80+	50,000	Yes
38936	LED9T8/G/2/840	T8	Med Bi-Pin (G13)	8	20	24"	1100	4000	80+	50,000	Yes
38939	LED9T8/G/2/850	T8	Med Bi-Pin (G13)	8	20	24"	1100	5000	80+	50,000	Yes
38943	LED9T8/G/2/865	T8	Med Bi-Pin (G13)	8	20	24"	1000	6500	80+	50,000	-
3ft LED Tube											
38257	LED18T8/G/3/830	T8	Med Bi-Pin (G13)	16	20	36"	1800	3000	80+	50,000	-
38258	LED18T8/G/3/835	T8	Med Bi-Pin (G13)	16	20	36"	1800	3500	80+	50,000	-
38260	LED18T8/G/3/840	T8	Med Bi-Pin (G13)	16	20	36"	1900	4000	80+	50,000	-
38261	LED18T8/G/3/850	T8	Med Bi-Pin (G13)	16	20	36"	1900	5000	80+	50,000	-
4ft LED Tube											
76194	LED12T8/G/4/830	T8	Med Bi-Pin (G13)	10	20	48"	1550	3000	80+	50,000	Yes
76264	LED12T8/G/4/835	T8	Med Bi-Pin (G13)	10	20	48"	1600	3500	80+	50,000	Yes
76265	LED12T8/G/4/840	T8	Med Bi-Pin (G13)	10	20	48"	1650	4000	80+	50,000	Yes
76271	LED12T8/G/4/850	T8	Med Bi-Pin (G13)	10	20	48"	1650	5000	80+	50,000	Yes
76278	LED12T8/G/4/865	T8	Med Bi-Pin (G13)	10	20	48"	1650	6500	80+	50,000	-
38944	LED15T8/G/4/830	T8	Med Bi-Pin (G13)	13	20	48"	1700	3000	80+	50,000	Yes
38945	LED15T8/G/4/835	T8	Med Bi-Pin (G13)	13	20	48"	1750	3500	80+	50,000	Yes
38950	LED15T8/G/4/840	T8	Med Bi-Pin (G13)	13	20	48"	2200	4000	80+	50,000	Yes
38951	LED15T8/G/4/850	T8	Med Bi-Pin (G13)	13	20	48"	1800	5000	80+	50,000	Yes
38952	LED15T8/G/4/865	T8	Med Bi-Pin (G13)	13	20	48"	1800	6500	80+	50,000	-
TBD	LED21T8/G/4/830	T8	Med Bi-Pin (G13)	18	20	48"	2200	3000	80+	50,000	Yes
62428	LED21T8/G/4/835	T8	Med Bi-Pin (G13)	18	20	48"	2400	3500	80+	50,000	Yes
62485	LED21T8/G/4/840	T8	Med Bi-Pin (G13)	18	20	48"	2500	4000	80+	50,000	Yes
62487	LED21T8/G/4/850	T8	Med Bi-Pin (G13)	18	20	48"	2500	5000	80+	50,000	Yes

Lightech Drivers - Non Dimming

GE Product Code	Description	# of Lamps
93100	LED9T8/DR/UN/2L	2
76289	LED12T8/DR/2L	2
38970	LED15T8/DR/UN/2L	2
82347	LED18T8/DR/UN/2L	2
94384	LED21T8/DR/1L	1
94385	LED21T8/DR/2L	2

Lightech Drivers - Dimming

GE Product Code	Description	# of Lamps
76290	LED12T8/DR/D2L	2
76318	LED12T8/DR/4DL	4
38974	LED15T8/DR/D2L	2
38975	LED15T8/DR/4DL	4
88141	LED18T8/DR/D2L	2
88139	LED18T8/DR/4DL	4
60041	LED21T8/DR/D/2L	2
34016	LED21T8/DR/VLC/2L	2
62030	LED21T8/DR/D/4L	4

General Characteristics - Non Dimming

GE Product Code	76289	38970	82347	94384	94385
Output Current (A)	0.21*2	0.44*2	0.53*2	0.62	0.62*2
Input Watt (Max)	24	30	36	21	42
Input Voltage (V)	120-277V				
Input Frequency (Hz)	50/60Hz				
Efficiency (%)	> .9%				
Output Type	DC				
Output Volt Range	27-33V				
Dimmability	None				
Ambient Temp Min	-4°F				
Ambient Temp Max	113°F				
Case Temperature	158°F				

General Characteristics - Dimming

GE Product Code	88141	76290	38974	60041	34016	38975	62030	76318	88139
Output Current (A)	0.53*2	0.21*2	0.44*2	0.62*2	0.62*2	0.44*4	0.62*4	0.21*4	0.53*4
Input Watt (Max)	36	24	30	42	42	60	84	48	72
Input Voltage (V)	120-277V								
Input Frequency (Hz)	50/60Hz								
Efficiency (%)	> .9%								
Output Type	DC								
Output Volt Range	27-33V								
Dimmability	0-10V								
Ambient Temp Min	-4°F								
Ambient Temp Max	113°F								
Case Temperature	158°F								

Dimensions - Non Dimming

GE Product Code	82437	76289	38970	94384	94385
Weight	1.01	1.01	1.01	1.01	1.01
Casing Length (in)	9.5				
Casing Width (in)	1.3				
Casing Height (in)	1				
Lead Exit Length (in)	26				
Input Wire Length (in)	36				
Output Wire Length (in)	38				

Dimensions - Dimming

GE Product Code	76290	38974	34016	60041	38975	62030	76318
Weight	1.01			1.08			
Casing Length (in)	9.5			9.5			
Casing Width (in)	1.3			1.7			
Casing Height (in)	1			1			
Lead Exit Length (in)	26			26			
Input Wire Length (in)	36			36			
Output Wire Length (in)	38			42			

ecomaginationSM



Product is compliant with material restriction requirements of RoHS



www.gelighting.com

GE and the GE Monogram are trademarks of the General Electric Company. All other trademarks are the property of their respective owners. Information provided is subject to change without notice. All values are design or typical values when measured under laboratory conditions. GE Lighting and GE Lighting Solutions, LLC are businesses of the General Electric Company. © 2016 GE.

LEDL017 (Rev 10/27/16)

Refit Solutions from GE



Application illustration only, subject lamps not used in photo.

Type C LED Tubes - High Lumen Glass

Convert your existing linear fluorescent fixture to LED lighting without needing a comprehensive reinstall. LED High Lumen Glass tubes are ideal for those seeking higher light levels while saving energy. Requires minimal installation time with a 5 year system warranty. Each LED tube is operated by a GE Lightech™ driver. See reverse for LED tubes and Lightech driver product details.

FEATURES

- 4' glass tube
- 2,700 -2,800 lumens
- > 133 total system lumens per watt (LPW)
- 3500K, 4000K and 5000K color temperature
- 50,000-hour rated life
- Open or enclosed fixtures
- 5 year warranty
- UL and cUL listed

BENEFITS

- Fast and Easy LED upgrade
- Low energy LFL replacement
- 66% longer life than LFL (50,000 vs. 30,000 hours)
- Better quality of light
 - instant on
- No UV (Ultra Violet Rays)
- Fully illuminates fixture
 - >270 light distribution
- Easy disposal, non-hazardous waste

To learn more about saving money and energy, go to: gelighting.com/ThinkLED

When you Think LED lighting, Think GE.

ecomaginationSM



imagination at work

Information provided is subject to change without notice. Please verify all details with GE. All values are design or typical values when measured under laboratory conditions, and GE makes no warranty or guarantee, expressed or implied, that such performance will be obtained under end-use conditions.

Product Specifications

Refit LED Tubes

GE Product Code	Description	Bulb Shape	Base	Watts	Case Quantity	Length (in)	Initial Lumens	Color Temp (K°)	CRI	*Rated Life L70 (Hrs)
62406	LED21T8/G4/835HL	T8	Med Bi-Pin (G13)	18	10	48"	2750	3500	80	50,000
62407	LED21T8/G4/840HL	T8	Med Bi-Pin (G13)	18	10	48"	2800	4000	80	50,000
62408	LED21T8/G4/850HL	T8	Med Bi-Pin (G13)	18	10	48"	2800	5000	80	50,000

Lightech Drivers - Non Dimming

GE Product Code	Description	# of Lamps
94384	LED21T8/DR/1L	1
94385	LED21T8/DR/2L	2

Lightech Drivers - Dimming

GE Product Code	Description	# of Lamps
60041	LED21T8/DR/D/2L	2
34016	LED21T8/DR/VLC/2L	2
62030	LED21T8/DR/D/4L	4

General Characteristics - Non Dimming

GE Product Code	94384	94385
Output Current (A)	0.62	0.62*2
Input Watt (Max)	21	42
Input Voltage (V)	120-277V	
Input Frequency (Hz)	50/60Hz	
Efficiency (%)	> .9%	
Output Type	DC	
Output Volt Range	26-34V	
Dimmability	None	
Ambient Temp Min	-4°F	
Ambient Temp Max	113°F	
Case Temperature	158°F	

General Characteristics - Dimming

GE Product Code	60041	34016	62030
Output Current (A)	0.62*2	0.62*2	0.62*4
Input Watt (Max)	42	42	84
Input Voltage (V)	120-277V		
Input Frequency (Hz)	50/60Hz		
Efficiency (%)	> .9%		
Output Type	DC		
Output Volt Range	26-34V		
Dimmability	0-10V		
Ambient Temp Min	-4°F		
Ambient Temp Max	113°F		
Case Temperature	158°F		

Dimensions - Non Dimming

GE Product Code	94384	94385
Weight	1.01	1.01
Casing Length (in)	9.5	
Casing Width (in)	1.3	
Casing Height (in)	1	
Lead Exit Length (in)	26	
Input Wire Length (in)	36	
Output Wire Length (in)	38	

Dimensions - Dimming

GE Product Code	34016	60041	62030
Weight	1.01	1.08	
Casing Length (in)	9.5		
Casing Width (in)	1.7		
Casing Height (in)	1		
Lead Exit Length (in)	26		
Input Wire Length (in)	36		
Output Wire Length (in)	42		

ecomaginationSM



Product is compliant with material restriction requirements of RoHS



www.gelighting.com

GE and the GE Monogram are trademarks of the General Electric Company. All other trademarks are the property of their respective owners. Information provided is subject to change without notice. All values are design or typical values when measured under laboratory conditions. GE Lighting and GE Lighting Solutions, LLC are businesses of the General Electric Company. © 2016 GE.

LEDL018 (Rev 10/27/16)

Refit Solutions

LED tubes with Lightech™ driver



BEFORE YOU BEGIN

Read these instructions completely and carefully.

Save These Instructions

These Instructions do not purport to cover all details or variations in components nor to provide for every possible contingency to be met in connection with installation, operation or maintenance. Should further information be desired or should particular problem arise which are not covered sufficiently for the purchaser's purpose, the matter should be referred to General Electric Company. GE Lighting does not claim liability for any installation not performed according to this guide or not by a qualified electrician.

For Your Safety

Read and observe all **CAUTIONS** and **WARNINGS** shown throughout these instructions.

- Installation to be performed by factory trained or qualified personnel. Ensure this manual is provided to the installers and users.
- Use this product only in the manner intended by the manufacturer. If there are any questions or concerns, contact the manufacturer.
- This tube is designed for indoor application only, and should not be used in environment of high temperature and high humidity.
- LED tubes & Lightech LED drivers (products SKUs on last page of this installation guide) are sold separately. Do not operate LED tubes without the corresponding Lightech LED driver.
- This device is not intended for use with Emergency exits.
- Suitable for dry location.
- Suitable for "Type IC" or "Type non-IC" luminaires.
- Max. 4pcs LED tubes can be operated in a luminaire.

Provided Components

The components have been properly packed to avoid damage during transit. Inspect the components to confirm there is no physical damage. Do not install damaged components.

The carton consists of:

- LED tubes
- Drivers
- Instruction sheet
- Labels

Tools and Components Required

- Screwdriver (6-12mm)
- Wire cutters

WARNING

RISK OF FIRE OR ELECTRIC SHOCK

- Disconnect power before installation or maintenance. Contact a qualified electrician for installation.
- LED Retrofit Kit installation requires knowledge of luminaires electrical systems. If not qualified, do not attempt installation. Contact a qualified electrician.
- Install this kit only in the luminaires that have the construction features and dimensions shown in the photographs and/or drawings.
- To prevent wiring damage or abrasion, do not expose wiring to edges of sheet metal or other sharp objects. Installers should not disconnect existing wires from lampholder terminals to make new connections at lampholder terminals. Instead installers should cut existing lampholder leads away from the lampholder and make new electrical connections to lampholder lead wires by employing applicable connectors.

CAUTION

RISK OF INJURY

- Tube may fall down if not installed properly, follow installation instructions.
- Wear safety glasses and proper aid during installation and maintenance.

RISK OF PRODUCT DAMAGE

- Do not replace conventional LFL directly with LED tubes. LED tubes need a DC voltage to work.



imagination at work

Components Installation

- 1** Ensure that the power to the unit is turned off. Use proper lockout and tagout procedures.

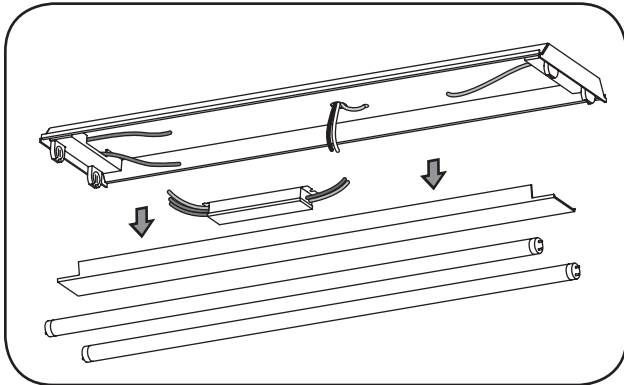

- 2** Remove existing lamps, fixture coverplate, and ballast. Replace lamp holders if necessary. Leave wiring in place and make sure wire length is long enough to attach to the new LED driver. Verify that the AC supply line is provided with a ground wire connected to the luminaire.

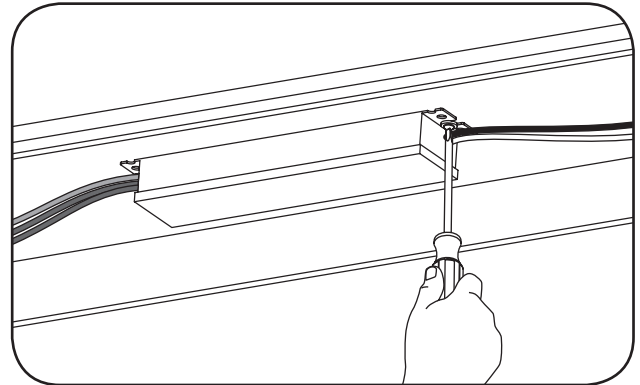

- 3** Secure Lighttech driver to fixture by using existing ballast mounting holes and screws. Use self-tapping screws (not provided) to create new mounting holes if necessary.

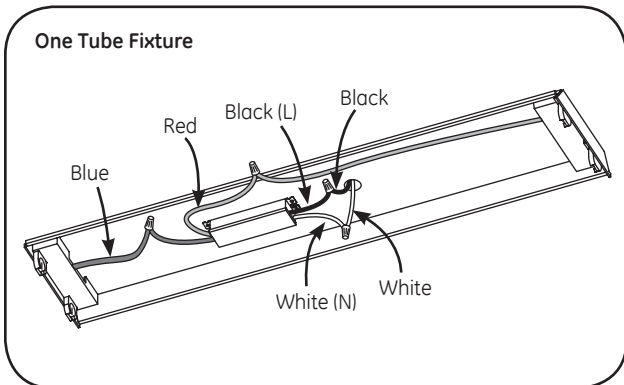

- 4A** Connect the black (L) and white (N) wires of driver to black and white wires of AC line, respectively. Connect each blue wire of the driver to each lampholder at one end. Then at the opposite end, connect the red wire of the driver to one lamp holder.

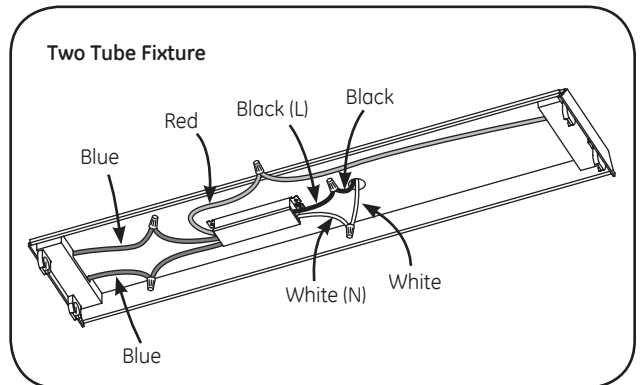

4B

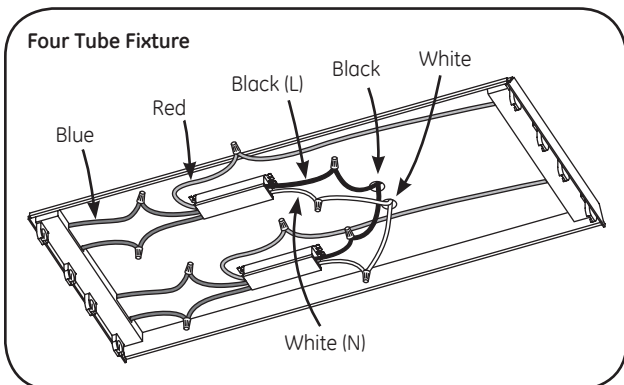

4C

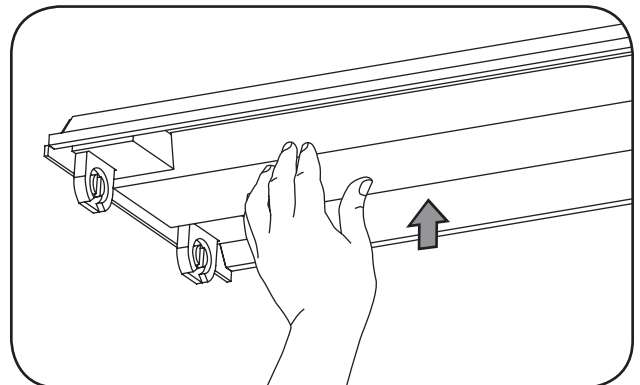

- 5** Compact wires and reattach fixture coverplate.

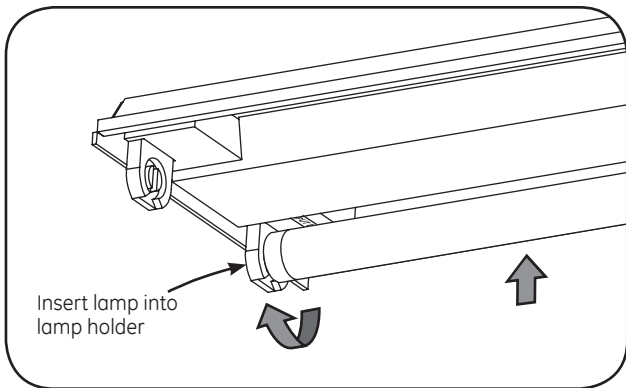

6 Insert the correct and marked end of the LED tube into the lamp holder of the fixture and rotate 90 degrees. Repeat for remaining tubes.

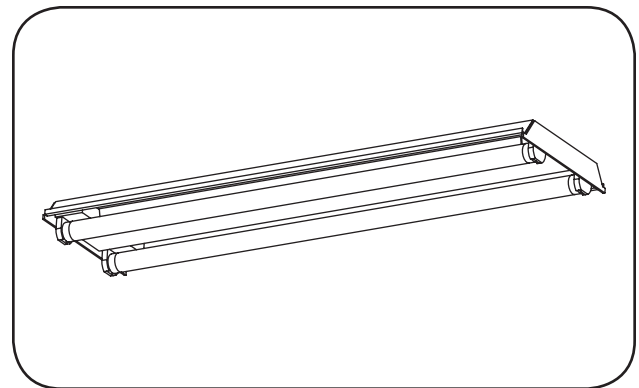

7 Restore power and ensure lamps are operating correctly.

Maintenance/Lamp Replacement

Contact qualified electrician for the maintenance service. Order any replacement parts individually with the exact same model number. For any questions or concerns contact the manufacturer.

Product Information

Bulb Shape	Base	Watts	PC	Description	Case Qty	MOL (in)	Initial Lumens	Color Temp (K)	CRI	Rated Life (L70)	UL	Location Rating
T8	Medium Bi-Pin (G13)	18	94381	LED21T8/4/835	10	48	2,100	3500	80	50,000	Yes	Dry
T8	Medium Bi-Pin (G13)	18	94382	LED21T8/4/840	10	48	2,100	4000	80	50,000	Yes	Dry
T8	Medium Bi-Pin (G13)	18	94383	LED21T8/4/850	10	48	2,200	5000	80	50,000	Yes	Dry

This device complies with Part 15 of the FCC Rules. Operation is subject to the following two conditions: (1) This device may not cause harmful interference, and (2) this device must accept any interference received, including interference that may cause undesired operation. This Class [B] RFLD complies with the Canadian standard ICES-003. Ce DEFR de la classe [B] est conforme à la NMB-003 du Canada.

Note: This equipment has been tested and found to comply with the limits for a Class B digital device, pursuant to part 15 of the FCC Rules. These limits are designed to provide reasonable protection against harmful interference when the equipment is operated in a commercial environment. This equipment generates, uses, and can radiate radio frequency energy and, if not installed and used in accordance with the instruction manual, may cause harmful interference to radio communications. Operation of this equipment in a residential area is likely to cause harmful interference in which case the user will be required to correct the interference at his own expense.



GE Lighting • www.gelighting.com

Information provided is subject to change without notice. Please verify all details with GE. All values are design or typical values when measured under laboratory conditions, and GE makes no warranty or guarantee, express or implied, that such performance will be obtained under end-use conditions. The GE brand and logo are registered trademarks of the General Electric Company © 2014.

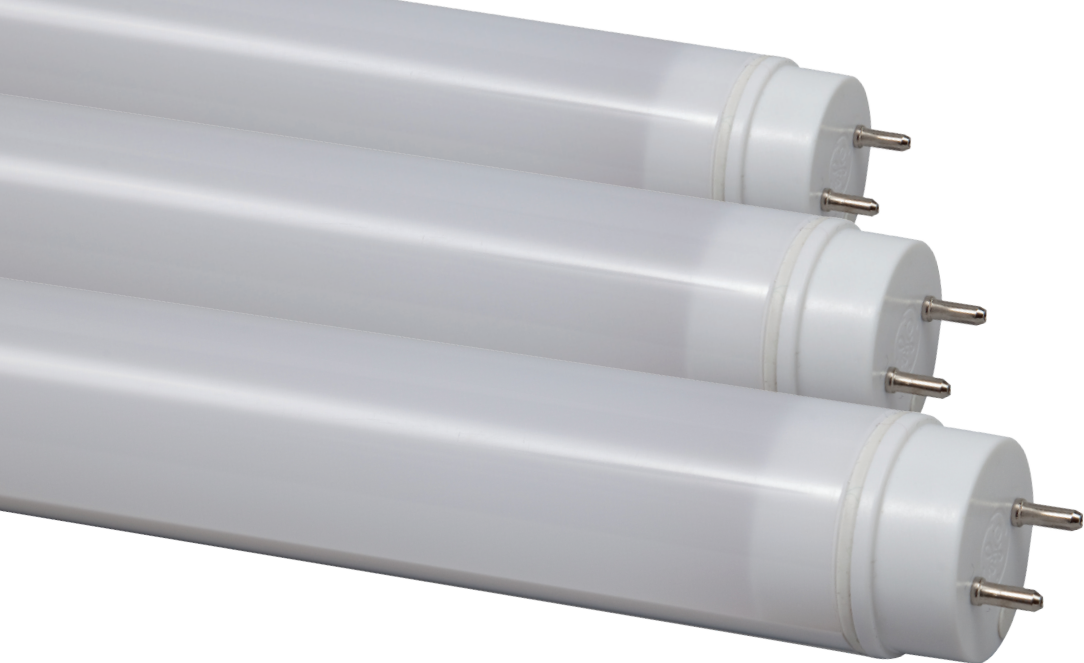

Considering LED Tubes

As an emerging lighting technology, LED linear tube options are raising questions throughout the industry—it's important to know the options and which one will work best for you.

Fluorescent lighting is universal; billions of these tubes can be found in warehouses, retail facilities and other large commercial spaces across the globe. Look up, and you'll likely find these familiar tubes lining the ceilings of many facilities.

But linear fluorescent tubes (LFLs) have largely reached their maximum technological potential. In contrast, LED lighting is rapidly evolving and providing an alternative to LFLs. Building and facility managers are adopting LED lighting for its long life span, energy efficiency and controllability. Now, with Refit Solutions from GE anywhere LFL is today, LED can exist tomorrow.



The Options

Three different types of LED linear tube options have emerged onto the market, as designated by Underwriters Laboratories (UL) under the UL 1598 certification. In order to make the best choice for your facility, it's important to consider the differences:



LED Tube with Integrated Driver - Compatible and Operated on Existing LFL Ballast



Description

This UL Type A tube, which will be offered by GE through its LED Tube with integrated Lightech™ driver, is designed with an internal driver that allows the tube to operate directly from the existing linear fluorescent ballast. Most of these products are designed to work with T12, T8 and T5 ballasts.

Advantages

UL Type A offers the simplest installation process—retrofitting involves a simple swap of the existing LFL with a UL Type A LED tube. Unlike the other options, no electrical or structural modification of the existing LFL fixture is required.

Disadvantages

However, with these benefits come some limitations. The lifetime of a UL Type A solution is dependent not only on the design life of the LED tube, but on the linear fluorescent ballast life, which could result in additional maintenance and costs within the lifetime of the product. Also, compatibility with various linear fluorescent ballasts on the market may vary, depending on different manufacturers and models.

Additionally, a UL Type A tube sacrifices efficiency due to the additional power loss from the existing ballast and is limited in dimming and controllability.

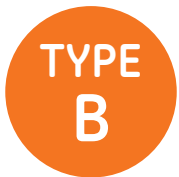

LED Tube with Integrated Driver - Wired to Mains



Description

Like the UL Type A, this UL Type B tube operates with an internal driver. However, UL Type B's internal driver is instead powered directly from the main voltage supplied to the existing LFL fixture, requiring several important and unique considerations.

Disadvantages

Installation of a UL Type B involves electrical modification to the existing fixture in order to connect the tube to the power supply. The existing LFL and its corresponding ballast must be removed from the fixture. Sockets may need to be replaced, and a connection is required from the fixture input wires directly to the sockets.

UL Type B is inherently more efficient than UL Type A, with no power loss from the removal of the existing LFL ballast, but it is similarly limited

in dimming and control capabilities.

It is important to note that the fixture's incoming power wires are connected directly to the sockets, meaning installers are potentially exposed to the main's voltage during installation. For safety reasons, strict adherence to installation instructions is critical when rewiring existing fixtures and utilizing UL Type B tubes. Safe installation can be completed, but total installation time and cost will increase because of high-voltage wiring.

GE does not anticipate that it will offer UL Type B tubes in North America.

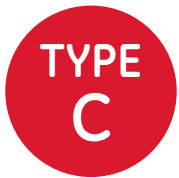

LED Tube with Remote Driver



Description

A UL Type C tube, offered among GE's Refit Solutions as the LED Tube with remote Lighttech™ driver, operates with a remote driver that powers the LED linear tube, rather than an integrated driver. Like UL Type B, UL Type C involves electrical modification to the existing fixture, but the low-voltage outputs of the driver are connected to the sockets instead of line voltage.

Advantages

Installation for UL Type C tubes involves removing existing tubes and ballasts, and it may involve

replacement of existing sockets. The fixture input wires must be connected to the LED driver, and the driver's low-voltage output wires must then be connected to the sockets before installing the new LED linear tubes. Once installed, this driver can power several LED tubes throughout the fixture.

The UL Type C offers the highest system efficacy, best system compatibility and greatest overall performance. It can be integrated with robust dimming and control functionality, helping to offset moderate labor and installation costs with heightened efficiency well into the future.

UL Considerations

If retrofitting an existing fixture that is UL approved with a UL-approved LED tube, the fixture will remain UL approved. If retrofitting an existing fixture that is not UL approved with a UL-approved LED tube, the fixture with the LED tubes would need to be submitted to UL for approval, if UL certification is necessary.

GE's Refit Solutions will keep intact the existing fixture's UL certification because Refit Solutions are certified by UL. GE customers must read the instructions provided with Refit Solutions prior to installation to understand inherent risks involved in altering existing systems.

As a more controllable technology than LFL, LED lighting can be successfully integrated into facilities' energy-efficiency planning. And with new LED tube options, the installation work can be done without as much hassle. GE's Refit Solutions can provide efficient LED lighting anywhere fluorescent tubes currently exist.

To learn more about GE's Refit Solutions or to schedule a professional lighting audit, please visit www.gelighting.com/refitsolutions.



www.gelighting.com/refitsolutions



www.gelighting.com

GE and the GE Monogram are trademarks of the General Electric Company. Information provided is subject to change without notice. All values are design or typical values when measured under laboratory conditions.
© 2014 GE Lighting.

16339 (Rev 07/28/14)

GE
Lighting

awaken



LED replacement lamps



ecomaginationSM



imagination at work

exceeding expectations

Why choose GE'S LED Lamps?

Innovation leadership

A GE scientist invented the first visible LED in 1962, pioneering a technology that is revolutionizing the lighting industry. That was our start and now we are dedicated to constantly improving LED performance. We continually invest in new products and the latest upgrades to make sure our best LED solutions are available.



Trust

We've been here. We'll be here. Built into each of GE's LED replacement lamps is 125 years of experience, reliability and innovation. Every performance claim we make is supported by stringent, comprehensive testing—ensuring that your lighting investment pays off today and in the future.

Long life

GE's LED replacement lamps are sturdy, dependable and long lasting. Depending on the lamp, you can expect up to 50,000 hours of rated life. That's 12 hours a day, every day of the year, for over a decade.

Short payback period

Decreased energy and maintenance costs, combined with utility rebates, deliver results that often exceed your expectations.





Family of solutions

Directional. Omni-directional. Decorative. Dimming. Tight optical control. Accent. Task. Display. Indoor. Outdoor. You name it. We've got it in LED.





LED replacement lamps

Decorative Lamps

Bulb Shape	Base Type	Watts	Order Code	Description	Volts	Case Qty**	MOL (In)	Lumens Initial	CBCP	Initial Color Temp	CRI	Wattage Replacement	*Rated Life L70 (Hrs)	Dimmable	ENERGY STAR® Status	#Location Rating	Additional Information	
Candles																		
	CA11	MED	3.5	68168	LED3DCAM-C/TP	120	3	4.2	170		2700	80	25W	15,000	Yes		Damp	Clear, Bent tip
			4	68167	LED4DCAM-F/TP	120	3	4.2	270		2700	82	25W	15,000	Yes		Damp	Frost, Bent tip
				21250	LED4DCAM-C3/827	120	6	4.2	300		2700	80	40W	15,000	Yes	★	Damp	Clear, Bent tip
				69111	LED4DCAM-C3/850	120	6	4.2	300		5000	80	40W	15,000	Yes	★	Damp	Clear, Bent tip
				75554	LED4DCAMCF/824	120	6	4.2	250		2400	80	25W	15,000	Yes		Damp	Clear, Bent tip
	CAND	3.5	7	21251	LED7DCAM-C3/827	120	6	4.8	500		2700	80	60W	15,000	Yes	★	Damp	Clear, Bent tip
			4	68166	LED3DCAC-C/TP	120	3	4.3	170		2700	80	25W	15,000	Yes		Damp	Clear, Bent tip
				68165	LED4DCAC-F/TP	120	3	4.3	270		2700	82	25W	15,000	Yes		Damp	Frost, Bent tip
				21231	LED4DCAC-C3/827	120	6	4.3	300		2700	80	40W	15,000	Yes	★	Damp	Clear, Bent tip
				69109	LED4DCAC-C3/850	120	6	4.3	300		2700	80	40W	15,000	Yes	★	Damp	Clear, Bent tip
				75553	LED4DCACCF/824	120	6	4.3	250		2400	80	25W	15,000	Yes		Damp	Clear, Bent tip
				21233	LED7DCAC-C3/827	120	6	4.8	500		2700	80	60W	15,000	Yes	★	Damp	Clear, Bent tip
			Globes															
	G16.5	CAND	4.5	68169	LED4DG16C-W/TP	120	3	3.0	270		2700	82	25W	15,000	Yes		Damp	White
				68170	LED4DG16C-C/TP	120	3	3.0	270		2700	82	25W	15,000	Yes		Damp	Clear
	G25	MED	4.5	68171	LED4DG25M-W/TP	120	3	4.3	280		2700	82	25W	15,000	Yes		Damp	White
				68172	LED4DG25M-C/TP	120	3	4.3	280		2700	82	25W	15,000	Yes		Damp	Clear
				21253	LED5DG25-W3/827	120	6	4.3	350		2700	80	40W	15,000	Yes	★	Damp	White
				7	21255	LED7DG25-W3/827	120	6	4.3	500		2700	80	60W	15,000	Yes	★	Damp

Filament Lamps

Bulb Shape	Base Type	Watts	Order Code	Description	Volts	Case Qty**	MOL (In)	Lumens Initial	CBCP	Initial Color Temp	CRI	Wattage Replacement	*Rated Life L70 (Hrs)	Dimmable	ENERGY STAR® Status	#Location Rating	Additional Information	
Candles																		
	ST19	MED	5	33025	LED5DST19-V-OT2P	120	8	5	440		2500		40W	15,000	Yes		Damp	4, 2-packs, Vintage Filament
			3	76018	LED3DST19-V	120	6	5	440		2500		25W	15,000	Yes		Damp	Vintage Filament
	CA11	E12	3	75915	LED3DCAC-V	120	6	4.4	300		2500	80	40W	15,000	Yes		Damp	Bent Tip, Vintage Filament
			3	75914	LED3DCAM-V	120	6	4.4	300		2500	80	40W	15,000	Yes		Damp	Bent Tip, Vintage Filament

Updated / New Product

Information provided is subject to change without notice. Please verify all details with GE. All values are design or typical values when measured under laboratory conditions, and GE makes no warranty or guarantee, expressed or implied, that such performance will be obtained under end-use conditions.

* The life rating is based on the hours of operation the lamp will provide before reaching 70% of its original rating (L70)

** Minimum order quantity = 6

★ ENERGY STAR® status: ENERGY STAR® certified. Lamps without a ★ are not ENERGY STAR® certified.

UL 1993 Environmental Requirements for LED LAMPS

Location, damp - Exterior or interior location that is normally or periodically subject to condensation of moisture in, on, or adjacent to, electrical equipment, and includes partially protected locations.

Location, dry - Location not normally subject to dampness, may include a location subject to temporary dampness, i.e., building under construction, provided ventilation is adequate to prevent an accumulation of moisture.



Location, wet - Location in which water or other liquid can drip, splash, or flow on or against electrical equipment.

Notes: 1) Product descriptions ending in "/TP" indicate a carded blister or clamshell package nested in a tray for shelf display. Cards also designed for hook display.

Get more information at
GELighting.com/ThinkLED

LED replacement lamps

A-Line Lamps

Bulb Shape	Base Type	Watts	Order Code	Description	Volts	Case Qty**	MOL (In)	Lumens Initial	CBCP	Initial Color Temp	CRI	Wattage Replacement	*Rated Life L70 (Hrs)	Dimmable	ENERGY STAR® Status	#Location Rating	Additional Information
	MED	4	34038	LED4DA15-W3/827	120	6	3.5	300		2700	80	40W	15,000	Yes		Damp	White
			34051	LED4DA15-C3/827	120	6	3.5	300		2700	80	40W	15,000	Yes		Damp	Clear
	MED	6	69115	LED6DA19/827	120	6	4.4	480		2700	80	40W	15,000	Yes	★	Damp	White, Omni, ES 2.0
			69118	LED6DA19/830	120	6	4.4	480		3000	80	40W	15,000	Yes	★	Damp	White, Omni, ES 2.0
			69132	LED6DA19/840	120	6	4.4	480		4000	80	40W	15,000	Yes	★	Damp	White, Omni, ES 2.0
			69144	LED6DA19/850	120	6	4.4	480		5000	80	40W	15,000	Yes	★	Damp	White, Omni, ES 2.0
			14063	LED7DAV3/827W	120	6	4.6	470		2700	80	40W	25,000	Yes		Damp	White, Semi-Omni
	MED	7	95928	LED7DAV3/5K	120	6	4.6	500		5000	80	40W	25,000	Yes		Damp	White, Semi-Omni
			11332	LED7DA19/827	120	6	4.4	450		2700	80	40W	25,000	Yes		Damp	White, Omnidirectional
			71208	LED7DA19/830	120	6	4.4	450		3000	80	40W	25,000	Yes		Damp	White, Omnidirectional
			34238	LED7DA19/824	120	6	4.44	450		2400	80	40W	25,000	Yes		Damp	White
			69117	LED10DA19/827	120	6	4.4	800		2700	80	60W	15,000	Yes	★	Damp	White, Omni, ES 2.0
	MED	10	69119	LED10DA19/830	120	6	4.4	800		3000	80	60W	15,000	Yes	★	Damp	White, Omni, ES 2.0
			69133	LED10DA19/840	120	6	4.4	800		4000	80	60W	15,000	Yes	★	Damp	White, Omni, ES 2.0
			69146	LED10DA19/850	120	6	4.4	800		5000	80	60W	15,000	Yes	★	Damp	White, Omni, ES 2.0
			13791	LED11DAV3/827W	120	6	4.6	800		2700	80	60W	15,000	Yes		Damp	White, Semi-Omni
			95927	LED11DAV3/5K	120	6	4.4	850		5000	80	60W	15,000	Yes		Damp	White, Semi-Omni
MED	11	11328	LED11DA19/827	120	6	4.4	800		2700	80	60W	25,000	Yes		Damp	White, Omnidirectional	
		71209	LED11DA19/830	120	6	4.4	800		3000	80	60W	25,000	Yes		Damp	White, Omnidirectional	
		29268	LED11DA19/824	120	6	4.44	800		2400	80	60W	25,000	Yes		Damp	White, Omnidirectional	
		74357	LED11DA19827GU24	120	6	5.43	800		2700	80	60W	25,000	Yes		Damp	White, Omnidirectional	
			GU24	12	73384	LED12A21/830FE	120	6	5.31	1100		3000	80	75W	25,000	Yes	
73404	LED12DA21/850FE				120	6	5.31	1100		5000	80	75W	25,000	Yes		Damp	White, Enclosed, Omni
MED	13		12422	LED13DA212/827	120	6	5.28	1100		2700	80	75W	25,000	Yes		Damp	White, Omnidirectional
			94936	LED14DA21/827W	120	6	5.3	1100		2700	80	75W	15,000	Yes		Damp	White, Semi-Omni
			12349	LED16DA212/827	120	6	5.28	1600		2700	80	100W	25,000	Yes		Damp	White, Omnidirectional
MED	16		12399	LED16DA212/830	120	6	5.3	1600		3000	80	100W	25,000	Yes		Damp	White, Omnidirectional
			92498	LED16DA21827GU24	120	6	5.43	1600		2700	80	100W	25,000	Yes		Damp	White, Omnidirectional
MED	16		73376	LED16A30/100/827	120	6	5.31	360/1400/900		2700	80	30/70/100	25,000	-	★	Damp	3-Way
			92118	LED16A30/100/5KB	120	3	5.31	400/1600/1050		5000	80	30/70/100	25,000	-	★	Damp	3-Way
			16113	LED17DA21/827	120	6	5.3	1600		2700	78	100W	15,000	Yes		Damp	White, Semi-Omni
		73378	LED22A50/150/827	150	6	5.31	700/2155/1600		2700	80	50/100/150	25,000	-		Damp	3-Way	
		92120	LED22A50/150/5KB	120	3	5.31	700/2155/1600		5000	80	50/100/150	25,000	-		Damp	3-Way	

LED Bright Stik™

Bulb Shape	Base Type	Watts	Order Code	Description	Volts	Case Qty**	MOL (In)	Lumens Initial	CBCP	Initial Color Temp	CRI	Wattage Replacement	*Rated Life L70 (Hrs)	Dimmable	ENERGY STAR® Status	#Location Rating	Additional Information
	MED	5.5	66256	LED5.5LS3/827	120	48	4.45	450		2700	80	40W	15,000	-	★	Damp	Case = 16 3-packs, ES 2.0
			75177	LED5.5LS3/850	120	48	4.45	450		5000	80	40W	15,000	-	★	Damp	Case = 16 3-packs, ES 2.0
	MED	6	35517	LED6LS3/828	120	48	4.45	450		2850	80	40W	15,000	-		Indoor	Case = 16 3-packs
			35519	LED6LS3/850	120	48	4.45	450		5000	80	40W	15,000	-		Indoor	Case = 16 3-packs
	MED	9	75184	LED9LS3/827	120	48	4.45	800		2700	80	60W	15,000	-	★	Damp	Case = 16 3-packs, ES 2.0
			75588	LED9LS3/850	120	48	4.45	800		5000	80	60W	15,000	-	★	Damp	Case = 16 3-packs, ES 2.0
	MED	10	28089	LED10LS3/828	120	48	4.45	760		2800	80	60W	15,000	-		Indoor	Case = 16 3-packs
			32273	LED10LS3/850	120	48	4.45	760		5000	80	60W	15,000	-		Indoor	Case = 16 3-packs
	MED	14	35520	LED14LS2/828	120	32	5.24	1060		2850	80	75W	15,000	-		Indoor	Case = 16 2-packs
			35522	LED14LS2/850	120	32	5.24	1060		5000	80	75W	15,000	-		Indoor	Case = 16 2-packs
	MED	16	35523	LED16LS2/828	120	32	5.24	1520		2850	80	100W	15,000	-		Indoor	Case = 16 2-packs
			35524	LED16LS2/850	120	32	5.24	1520		5000	80	100W	15,000	-		Indoor	Case = 16 2-packs

Updated / New Product

Information provided is subject to change without notice. Please verify all details with GE. All values are design or typical values when measured under laboratory conditions, and GE makes no warranty or guarantee, expressed or implied, that such performance will be obtained under end-use conditions.

* The life rating is based on the hours of operation the lamp will provide before reaching 70% of its original rating (L70)

** Minimum order quantity = 6

★ ENERGY STAR® status: ENERGY STAR® certified. Lamps without a ★ are not ENERGY STAR® certified.

UL 1993 Environmental Requirements for LED LAMPs

Location, damp - Exterior or interior location that is normally or periodically subject to condensation of moisture in, on, or adjacent to, electrical equipment, and includes partially protected locations.

Location, dry - Location not normally subject to dampness, may include a location subject to temporary dampness, i.e., building under construction, provided ventilation is adequate to prevent an accumulation of moisture.



Location, wet - Location in which water or other liquid can drip, splash, or flow on or against electrical equipment.

Notes: 1) Product descriptions ending in "/TP" indicate a carded blister or clamshell package nested in a tray for shelf display. Cards also designed for hook display.





Get more information at
GELighting.com/ThinkLED

LED replacement lamps

Reflector Lamps

Bulb Shape	Base Type	Watts	Order Code	Description	Volts	Case Qty**	MOL (In)	Lumens Initial	CBCP	Initial Color Temp	CRI	Wattage Replacement	*Rated Life L70 (Hrs)	Dimmable	ENERGY STAR® Status	#Location Rating	Additional Information	
R20																		
	MED	7	38268	LED7DR20/827	120	6	3.64	470		2700	80		25,000	Yes		Damp	White	
			43233	LED7DR20/830	120	6	3.64	470		3000	80		25,000	Yes		Damp	White	
			38273	LED7DR20/850	120	6	3.64	500		5000	80		25,000	Yes		Damp	White	
BR30																		
	MED	10	68160	LED10DR303/827W	120	6	5.4	700		2700	80	65W	25,000	Yes	★	Damp	Frosted, White body	
			68161	LED10DR303/830W	120	6	5.4	700		3000	80	65W	25,000	Yes	★	Damp	Frosted, White body	
			69107	LED10DR303/850W	120	6	5.4	700		3000	80	65W	25,000	Yes	★	Damp	Frosted, White body	
			43234	LED10DR30V/827W	120	3	5.37	650		2700	80	65W	15,000	Yes		Damp	Frosted, White body	
			43237	LED10DR30V/830W	120	3	5.37	650		3000	80	65W	15,000	Yes		Damp	Frosted, White body	
			43241	LED10DR30V/850W	120	3	5.37	650		5000	80	65W	15,000	Yes		Damp	Frosted, White body	
BR40																		
	MED	13	64176	LED13DBR40/827	120	6	6.3	1070		2700	80	85W	25,000	Yes	★	Damp	Frosted, White body	
			14708	LED13DBR40/830	120	6	6.3	1070		3000	80	85W	25,000	Yes	★	Damp	Frosted, White body	
			20445	LED13BR40/5K/TP	120	3	6.34	1070		5000	80	85W	25,000	Yes	★	Damp	Frosted, White body	

Directional Lamps (MR16 - GU10)

Bulb Shape	Base Type	Watts	Order Code	Description	Volts	Case Qty**	MOL (In)	Lumens Initial	CBCP	Initial Color Temp	CRI	Wattage Replacement	*Rated Life L70 (Hrs)	Dimmable	ENERGY STAR® Status	#Location Rating	Additional Information		
12 Volt AC/DC MR16																			
	MR16	GU5.3	7	93412	LED7DMR16S830/15	12	6	2.3	460	3800	3000	80	35W	25,000	Yes		Damp	Spot 15° beam, Silver	
				69920	LED7DMR16D830/25	12	6	1.9	390	1900	3000	83	35W	25,000	Yes		Damp	Narrow Flood 25° beam, Silver	
				93433	LED7DMR16S840/15	12	6	1.97	490	4200	4000	80	35W	25,000	Yes		Damp	Accent, 15° beam, Silver	
	MRX16	GU5.3	7	35196	LED7XDMRX1683025	12	6	2.2	500	1350	3000	80	50W	25,000	Yes	★	Damp	Flood 35° beam, White	
				35206	LED7XDMRX1682725	12	6	2.2	480	2350	2700	80	50W	25,000	Yes	★	Damp	Narrow Flood 25° beam, White	
				35195	LED7XDMRX1683025	12	6	2.2	500	2350	3000	80	50W	25,000	Yes	★	Damp	Narrow Flood 25° beam, White	
				35196	LED7XDMRX1683035	12	6	2.2	500	1350	3000	80	50W	25,000	Yes	★	Damp	Flood 35° beam, White	
				35206	LED7XDMRX1682725	12	6	2.2	500	2350	2700	80	50W	25,000	Yes	★	Damp	Narrow Flood 25° beam, White	
				35214	LED7XDMRX1682735	12	6	2.2	500	1350	2700	80	50W	25,000	Yes	★	Damp	Flood 35° beam, White	
				35529	LED7DMRX15827/15	12	6	2.2	400	3400	2700	80	35W	25,000	Yes		Damp	Spot 15° beam, White	
				21359	LED7MRX16R930/10	12	6	2.01	350	8000	3000	95	50W	25,000	-		Damp	Spot, 10° beam, Reveal	
Value 12 Volt AC/DC MR16																			
	MR16	GU5.3	5.5	35542	LED5.5DMR1684035	12	6	1.8	460	1100	4000	80	35W	25,000	Yes	★	Damp	Flood, 35° beam, White	
				35535	LED5.5DMR1683035	12	6	1.88	420	1000	3000	80	35W	25,000	Yes	★	Damp	Flood, 35° beam, White	
				35540	LED5.5DMR1682735	12	6	1.88	400	1000	2700	80	35W	25,000	Yes	★	Damp	Flood, 35° beam, White	
				7	39542	LED7XDMR16-V2725	12	6	1.88	530	2400	2700	80	50W	25,000	Yes		Damp	Narrow Flood, 25° beam, White
				39567	LED7XDMR16-V2735	12	6	1.88	530	1400	2700	80	50W	25,000	Yes		Damp	Flood, 35° beam, White	
				35543	LED7XDMR16-28325	12	6	1.8	500	2350	3000	80	50W	25,000	Yes	★	Damp	Narrow Flood, 25° beam, White	
120 Volt GU10																			
	MR16	GU10	3.5	37114	LED4D/GU1083035	120	6	2.1	250	550	3000	80	35W	25,000	Yes	★	Dry	Flood, 35° beam, White	
				4	89020	LED4D/GU10/NFLTP	120	3	2.1	250	720	3000	80	35W	25,000	Yes	★	Damp	Flood, 35° beam, White
				6	26346	LED6D/GU10/NFL/TP	120	3	2.1	380	1100	3000	80	50W	25,000	Yes	★	Damp	Flood, 35° beam, White

Updated / New Product

Information provided is subject to change without notice. Please verify all details with GE. All values are design or typical values when measured under laboratory conditions, and GE makes no warranty or guarantee, expressed or implied, that such performance will be obtained under end-use conditions.

* The life rating is based on the hours of operation the lamp will provide before reaching 70% of its original rating (L70)

** Minimum order quantity = 6

★ ENERGY STAR® status: ENERGY STAR® certified. Lamps without a "★" are not ENERGY STAR® certified.

UL 1993 Environmental Requirements for LED LAMPS

Location, damp - Exterior or interior location that is normally or periodically subject to condensation of moisture in, on, or adjacent to, electrical equipment, and includes partially protected locations.

Location, dry - Location not normally subject to dampness, may include a location subject to temporary dampness, i.e., building under construction, provided ventilation is adequate to prevent an accumulation of moisture.



Location, wet - Location in which water or other liquid can drip, splash, or flow on or against electrical equipment.

Notes: 1) Product descriptions ending in "/TP" indicate a carded blister or clamshell package nested in a tray for shelf display. Cards also designed for hook display.

Get more information at
GELighting.com/ThinkLED

LED replacement lamps



Directional Lamps (PAR16 - PAR20)

Bulb Shape	Base Type	Watts	Order Code	Description	Volts	Case Qty**	MOL (In)	Lumens Initial	CBCP	Initial Color Temp	CRI	Wattage Replacement	*Rated Life L70 (Hrs)	Dimmable	ENERGY STAR® Status	#Location Rating	Additional Information	
Compact PAR16																		
	MED	4	26383	LED4D/P16/NFLTP	120	3	2.8	250	720	3000	80	40W	25,000	Yes	★	Dry	Flood, 35° beam, White	
		6	26384	LED6D/P16/NFLTP	120	3	2.8	380	1100	3000	80	60W	25,000	Yes	★	Dry	Flood, 35° beam, White	
Compact PAR20																		
	MED	7	93327	LED7DP203B830/20	120	6	3.5	520	3600	3000	80	50W	25,000	Yes	★	Damp	Narrow Flood, 20° beam Black	
		93347	LED7DP203W830/20	120	6	3.5	520	3600	3000	80	50W	25,000	Yes	★	Damp	Narrow Flood, 20° beam White		
		93348	LED7DP203W830/35	120	6	3.5	520	1200	3000	80	50W	25,000	Yes	★	Damp	Flood, 35° beam White		
		93349	LED7DP203B827/20	120	6	3.5	500	3600	2700	80	50W	25,000	Yes	★	Damp	Narrow Flood, 20° beam Black		
		93354	LED7DP203B827/35	120	6	3.5	500	1150	2700	80	50W	25,000	Yes	★	Damp	Flood, 35° beam Black		
		93360	LED7DP203W827/20	120	6	3.5	500	3600	2700	80	50W	25,000	Yes	★	Damp	Narrow Flood, 20° beam White		
		93362	LED7DP203W827/35	120	6	3.5	500	1150	2700	80	50W	25,000	Yes	★	Damp	Flood, 35° beam White		

Directional Lamps (PAR30 - Low Glare - Visual Comfort Lens™)

Bulb Shape	Base Type	Watts	Order Code	Description	Volts	Case Qty**	MOL (In)	Lumens Initial	CBCP	Initial Color Temp	CRI	Wattage Replacement	*Rated Life L70 (Hrs)	Dimmable	ENERGY STAR® Status	#Location Rating	Additional Information	
Compact PAR30 - Low Glare - Visual Comfort Lens™																		
	MED	12	84374	LED12DP30RW93015	120	6	3.74	860	9400	3000	90	75W	25,000	Yes	★	Damp	Spot, 15° beam, White	
		84379	LED12DP30RW93025	120	6	3.74	900	3900	3000	90	75W	25,000	Yes	★	Damp	Narrow Flood, 25° beam, White		
		84380	LED12DP30RW93040	120	6	3.74	900	1800	3000	90	75W	25,000	Yes	★	Damp	Flood, 40° beam, White		
		84392	LED12DP30RW92725	120	6	3.74	850	3500	2700	90	75W	25,000	Yes	★	Damp	Narrow Flood, 25° beam, White		
		84395	LED12DP30RW92740	120	6	3.74	850	1700	2700	90	75W	25,000	Yes	★	Damp	Flood, 40° beam, White		
		84384	LED12DP30RW83025	120	6	3.74	1050	4800	3000	80	75W	25,000	Yes	★	Damp	Narrow Flood, 25° beam, White		
		42131	LED12DP30RW83040	120	6	3.74	1050	2400	3000	80	75W	25,000	Yes	★	Damp	Flood, 40° beam, White		
		42133	LED12DP30RW82725	120	6	3.74	1000	4700	2700	80	75W	25,000	Yes	★	Damp	Narrow Flood, 25° beam, White		
		42134	LED12DP30RW82740	120	6	3.74	1000	2200	2700	80	75W	25,000	Yes	★	Damp	Flood, 40° beam, White		
		73583	LED12DP30RB82740	120	6	3.74	1000	2200	2700	80	75W	25,000	Yes	★	Damp	Flood, 40° beam, Black		
		Compact PAR30 - Long Neck - Low Glare - Visual Comfort Lens™																
	MED	12	84399	LED12DP3LRW93025	120	6	4.72	900	3900	3000	90	75W	25,000	Yes	★	Damp	Narrow Flood, 25° beam, White	
		84400	LED12DP3LRW93040	120	6	4.72	900	1800	3000	90	75W	25,000	Yes	★	Damp	Flood, 40° beam, White		
		84407	LED12DP3LRW92740	120	6	4.72	850	1700	2700	90	75W	25,000	Yes	★	Damp	Flood, 40° beam, White		
		42136	LED12DP3LRW83025	120	6	4.72	1050	4800	3000	80	75W	25,000	Yes	★	Damp	Narrow Flood, 25° beam, White		
		42137	LED12DP3LRW83040	120	6	4.72	1050	2400	3000	80	75W	25,000	Yes	★	Damp	Flood, 40° beam, White		
		42141	LED12DP3LRW82725	120	6	4.72	1000	4700	2700	80	75W	25,000	Yes	★	Damp	Narrow Flood, 25° beam, White		
		42144	LED12DP3LRW82740	120	6	4.72	1000	2200	2700	80	75W	25,000	Yes	★	Damp	Flood, 40° beam, White		
		20151	LED17DP30LW93025	120	6	4.8	1100	4600	3000	90	75W	25,000	Yes	★	Damp	Spot, 25° beam, White		

Directional Lamps (PAR30 - STIR)

Bulb Shape	Base Type	Watts	Order Code	Description	Volts	Case Qty**	MOL (In)	Lumens Initial	CBCP	Initial Color Temp	CRI	Wattage Replacement	*Rated Life L70 (Hrs)	Dimmable	ENERGY STAR® Status	#Location Rating	Additional Information	
Compact PAR30																		
	MED	12	98755	LED12DP303W83035	120	6	3.66	950	2600	3000	80	75W	25,000	Yes	★	Damp	Flood, 35° beam, White, STIR	
Compact PAR30 Long Neck																		
	MED	12	98811	LED12DP3L3W83035	120	6	4.61	950	2600	3000	80	75W	25,000	Yes	★	Damp	Accent, 35° beam, White, STIR	

Directional Lamps (PAR30 - High Output)

Bulb Shape	Base Type	Watts	Order Code	Description	Volts	Case Qty**	MOL (In)	Lumens Initial	CBCP	Initial Color Temp	CRI	Wattage Replacement	*Rated Life L70 (Hrs)	Dimmable	ENERGY STAR® Status	#Location Rating	Additional Information	
Universal 120-277V																		
	MED	18	75089	LED18P30LW83015	120-277	6	4.6	1800	15500	3000	80	75W	25,000	-		Damp	Spot, 15°, White	
			75091	LED18P30LW83025	120-277	6	4.6	1800	7000	3000	80	75W	25,000	-		Damp	Narrow Flood, 25°, White	
			75065	LED18P30LW93015	120-277	6	4.6	1400	12500	3000	90	75W	25,000	-		Damp	Spot, 15° beam, MTO, 1000 Min. Qty, 12 Week Lead Time, White	
			75078	LED18P30LW93025	120-277	6	4.6	1400	5000	3000	90	75W	25,000	-		Damp	Narrow Flood, 25°, White	

Updated / New Product

Information provided is subject to change without notice. Please verify all details with GE. All values are design or typical values when measured under laboratory conditions, and GE makes no warranty or guarantee, expressed or implied, that such performance will be obtained under end-use conditions.

* The life rating is based on the hours of operation the lamp will provide before reaching 70% of its original rating (L70)

** Minimum order quantity = 6

★ ENERGY STAR® status: ENERGY STAR® certified. Lamps without a ★ are not ENERGY STAR® certified.

UL 1993 Environmental Requirements for LED LAMPS

Location, damp - Exterior or interior location that is normally or periodically subject to condensation of moisture in, on, or adjacent to, electrical equipment, and includes partially protected locations.

Location, dry - Location not normally subject to dampness, may include a location subject to temporary dampness, i.e., building under construction, provided ventilation is adequate to prevent an accumulation of moisture.

Location, wet - Location in which water or other liquid can drip, splash, or flow on or against electrical equipment.

Notes: 1) Product descriptions ending in "/TP" indicate a carded blister or clamshell package nested in a tray for shelf display. Cards also designed for hook display.

Get more information at
GELighting.com/ThinkLED

LED replacement lamps

Directional Lamps (PAR38 - Low Glare - Visual Comfort Lens™)

Bulb Shape	Base Type	Watts	Order Code	Description	Volts	Case Qty**	MOL (In)	Lumens Initial	CBCP	Initial Color Temp	CRI	Wattage Replacement	*Rated Life L70 (Hrs)	Dimmable	ENERGY STAR® Status	#Location Rating	Additional Information	
PAR38 - Low Glare - Visual Comfort Lens™																		
PAR38	MED	12	63323	LED12DP38W827/25	120	6	5.3	960	4600	2700	80	90W	25,000	Yes		Dry	Narrow Flood, 25° beam, White	
			63334	LED12DP38W927/25	120	6	5.3	820	3900	2700	91	90W	25,000	Yes		Dry	Narrow Flood, 25° beam, White	
			92971	LED12D38W3827/40	120	6	5.31	1050	2300	2700	81	100W	25,000	Yes	★	Damp	Flood, 40° beam, White	
			92972	LED12D38W3830/25	120	6	5.31	1050	5500	3000	81	100W	25,000	Yes	★	Damp	Narrow Flood, 25° beam, White	
			92973	LED12D38W3830/40	120	6	5.31	1050	2300	3000	80	100W	25,000	Yes	★	Wet	Flood, 40° beam, White	
			18	92923	LED18D38W3927/25	120	6	5.31	1250	4900	2700	92	100W	25,000	Yes	★	Damp	Narrow Flood, 25° beam, White
				92933	LED18D38W3930/25	120	6	5.31	1350	5200	3000	92	100W	25,000	Yes	★	Damp	Narrow Flood, 25° beam, White
				92927	LED18D38W3930/15	120	6	5.32	1350	15000	3000	92	75W	25,000	Yes	★	Wet	Spot, 15° beam, White
			92934	LED18D38W3930/40	120	6	5.12	1350	3200	3000	92	120W	25,000	Yes	★	Damp	Flood, 40° beam, White	
			92950	LED18D38W382725	120	6	5.12	1550	5800	2700	81	120W	25,000	Yes	★	Wet	Narrow Flood, 25° beam, White	
			92958	LED18D38W382740	120	6	5.12	1550	3800	2700	81	120W	25,000	Yes	★	Wet	Flood, 40° beam, White	
			92961	LED18D38W3830/15	120	6	5.12	1750	20000	3000	81	150W	25,000	Yes	★	Wet	Spot, 15° beam, White	
			92963	LED18D38W383025	120	6	5.12	1550	6000	3000	81	120W	25,000	Yes	★	Wet	Narrow Flood, 25° beam, White	
			92967	LED18D38W383040	120	6	5.12	1550	4000	3000	81	150W	25,000	Yes	★	Wet	Flood, 40° beam, White	
			92926	LED18D38W3927/40	120	6	5.12	1250	2900	2700	92	120W	25,000	Yes	★	Damp	Narrow Flood, 25° beam, White	
			93172	LED18D38W384040	120	6	5.31	1700	4400	4000	81	150W	25,000	Yes	★	Wet	Flood, 40° beam, White	
			65730	LED18D38W385025	120	6	5.31	1700	6500	5000	81	120W	25,000	Yes	★	Wet	Narrow Flood, 25° beam, White	
65731	LED18D38W385040	120	6	5.31	1700	4400	5000	81	150W	25,000	Yes	★	Wet	Flood, 40° beam, White				
93171	LED18D38W384025	120	6	5.31	1700	6500	4000	81	120W	25,000	Yes	★	Wet	Narrow Flood, 25° beam, White				
85085	LED18D38W383525	120	6	5.31	1700	6500	3500	81	120W	25,000	Yes	★	Wet	Narrow Flood, 25° beam, White				
87917	LED18D38W383540	120	6	5.31	1700	4400	3500	81	150W	25,000	Yes	★	Wet	Flood, 40° beam, White				

reveal® Whiter White Technology - PAR38

Bulb Shape	Base Type	Watts	Order Code	Description	Volts	Case Qty**	MOL (In)	Lumens Initial	CBCP	Initial Color Temp	CRI	Wattage Replacement	*Rated Life L70 (Hrs)	Dimmable	ENERGY STAR® Status	#Location Rating	Additional Information	
reveal® Whiter White Technology - PAR38																		
PAR38	MED	18	31300	LED18D38WW930/15	120	6	5.31	1170	10000	3000	91	100W	25,000	Yes	★	Damp	Spot, 15° beam, White, MTO, 1000 Min. Qty, 12 Week Lead Time	
			31301	LED18D38WW930/25	120	6	5.31	1170	4500	3000	91	100W	25,000	Yes	★	Damp	Narrow Flood, 25° beam, White	

Directional Lamps (Commercial PAR38)

Bulb Shape	Base Type	Watts	Order Code	Description	Volts	Case Qty**	MOL (In)	Lumens Initial	CBCP	Initial Color Temp	CRI	Wattage Replacement	*Rated Life L70 (Hrs)	Dimmable	ENERGY STAR® Status	#Location Rating	Additional Information			
Commercial PAR38 (Indoor/Outdoor)																				
PAR38	MED	12	90132	LED12DP382W82725	120	6	5.1	850	4000	2700	84	85W	25,000	Yes		Wet	Narrow Flood, 25° beam, White			
			26	68183	LED26DP38S830/12	120	6	5.3	1500	24000	3000	82	130W	25,000	Yes		Wet	Spot, 12° beam, Silver		
					68184	LED26DP38S830/25	120	6	5.3	1500	6800	3000	82	130W	25,000	Yes		Wet	Narrow Flood, 25° beam, Silver	
					68185	LED26DP38S830/40	120	6	5.3	1500	3100	3000	82	120W	25,000	Yes		Wet	Flood, 40° beam, Silver	
					68182	LED26DP38S840/40	120	6	5.3	1650	3200	4000	82	120W	25,000	Yes		Wet	Flood, 40° beam, Silver	
					33647	LED26DP38S835/12	120	6	5.3	1900	31000	3500	82	160W	25,000	Yes	★	Wet	Spot, 12° beam, Silver	
					70591	LED26DP38S835/40	120	6	5.3	1900	4000	3500	82	160W	25,000	Yes	★	Wet	Flood, 40° beam, Silver	
					28	15139	LED28P38S830/15	120	6	5.3	2400	20000	3000	81	150W	25,000	-	★	Damp	Spot, 15° beam, Silver, Non-Dimming
						25844	LED28P38S830/25	120	6	5.31	2400	11000	3000	81	150W	25,000	-	★	Damp	Narrow Flood, 25° beam, Silver, Non-Dim
						25953	LED28P38S830/40	120	6	5.31	2400	5,600	3000	81	150W	25,000	-	★	Damp	Flood, 40° beam, Silver, Non-Dimming

Directional Lamps (PAR38 - STIR)

Bulb Shape	Base Type	Watts	Order Code	Description	Volts	Case Qty**	MOL (In)	Lumens Initial	CBCP	Initial Color Temp	CRI	Wattage Replacement	*Rated Life L70 (Hrs)	Dimmable	ENERGY STAR® Status	#Location Rating	Additional Information	
Single Optics 15W PAR38																		
PAR38	MED	15	32213	LED15DP38W830/40	120	6	5.04	1300	2300	3000	81	90W	25,000	Yes	★	Wet	Flood, 40° beam, White, STIR	

Updated / New Product

Information provided is subject to change without notice. Please verify all details with GE. All values are design or typical values when measured under laboratory conditions, and GE makes no warranty or guarantee, expressed or implied, that such performance will be obtained under end-use conditions.

* The life rating is based on the hours of operation the lamp will provide before reaching 70% of its original rating (L70)

** Minimum order quantity = 6

★ ENERGY STAR® status: ENERGY STAR® certified. Lamps without a ★ are not ENERGY STAR® certified.

UL 1993 Environmental Requirements for LED LAMPS

Location, damp - Exterior or interior location that is normally or periodically subject to condensation of moisture in, on, or adjacent to, electrical equipment, and includes partially protected locations.

Location, dry - Location not normally subject to dampness, may include a location subject to temporary dampness, i.e., building under construction, provided ventilation is adequate to prevent an accumulation of moisture.

Location, wet - Location in which water or other liquid can drip, splash, or flow on or against electrical equipment.

Notes: 1) Product descriptions ending in "/TP" indicate a carded blister or clamshell package nested in a tray for shelf display. Cards also designed for hook display.



Get more information at
GELighting.com/ThinkLED

LED replacement lamps

LED HID

Bulb Shape	Base Type	Watts	Order Code	Description	Volts	Case Qty**	MOL (In)	Lumens Initial	CBCP	Initial Color Temp	CRI	Wattage Replacement	*Rated Life L70 (Hrs)	Dimmable	ENERGY STAR® Status	#Location Rating	Additional Information	
400 Watt Metal Halide Replacement Lamp																		
	EX39	165	21259	LED165/M400/740		3	11.42	20,000		4000	73	400	50,000	-		Dry	Open Rated, CWA, ANSI - M59, M135, M155	
	80	43258	LED80/2M250/740		3	8.4	11,800		4000	70	250W	50,000	-		Damp	Open or Enclosed Rated, CWA ANSI -M58, M138, M153		
	88099	LED80/2M250/750		3	8.4	11,800		5000	70	250W	50,000	-		Damp	Open or Enclosed Rated, CWA ANSI -M58, M138, M153			
	60	43263	LED60/2M175/740		3	8.4	8,800		4000	70	175W	50,000	-		Damp	Open or Enclosed Rated, CWA ANSI -M57, M137, M152		
	88107	LED60/2M175/750		3	8.4	8,800		5000	70	175W	50,000	-		Damp	Open or Enclosed Rated, CWA ANSI -M57, M137, M152			

Plug-In

Bulb Shape	Base Type	Watts	Order Code	Description	Volts	Case Qty**	MOL (In)	Lumens Initial	CBCP	Initial Color Temp	CRI	Wattage Replacement	*Rated Life L70 (Hrs)	Dimmable	#Location Rating	Additional Information	
Vertical																	
	Plug-In	G24q/GX24	12	96801	LED12G24Q-V/827	#	6	5.31	950	2700	80		50000	-	Damp	Requires Electronic Ballast, White	
				96775	LED12G24Q-V/830	#	6	5.31	950	3000	80		50000	-	Damp	Requires Electronic Ballast, White	
				96689	LED12G24Q-V/835	#	6	5.31	1000	3500	80		50000	-	Damp	Requires Electronic Ballast, White	
				96771	LED12G24Q-V/840	#	6	5.31	1000	4000	80		50000	-	Damp	Requires Electronic Ballast, White	
		GX24q	18.5	39288	LED19GX24q-V/827	#	6	6.42	1800	2700	80		50000	-	Damp	Requires Electronic Ballast, White	
				39277	LED19GX24q-V/830	#	6	6.42	1850	3000	80		50000	-	Damp	Requires Electronic Ballast, White	
				39275	LED19GX24q-V/835	#	6	6.42	1950	3500	80		50000	-	Damp	Requires Electronic Ballast, White	
				39279	LED19GX24q-V/840	#	6	6.42	1950	4000	80		50000	-	Damp	Requires Electronic Ballast, White	
Horizontal																	
	Plug-In	G24q/GX24	12	96799	LED12G24Q-H/827	#	6	5.31	950	2700	80		50000	-	Damp	Requires Electronic Ballast, White	
				96798	LED12G24Q-H/830	#	6	5.31	950	3000	80		50000	-	Damp	Requires Electronic Ballast, White	
				96761	LED12G24Q-H/835	#	6	5.31	1000	3500	80		50000	-	Damp	Requires Electronic Ballast, White	
				96769	LED12G24Q-H/840	#	6	5.31	1000	4000	80		50000	-	Damp	Requires Electronic Ballast, White	
		GX24q	18.5	39289	LED19GX24q-H/827	#	6	6.7	1800	2700	80		50000	-	Damp	Requires Electronic Ballast, White	
				39282	LED19GX24q-H/830	#	6	6.7	1850	3000	80		50000	-	Damp	Requires Electronic Ballast, White	
				39276	LED19GX24q-H/835	#	6	6.7	1950	3500	80		50000	-	Damp	Requires Electronic Ballast, White	
				39283	LED19GX24q-H/840	#	6	6.7	1950	4000	80		50000	-	Damp	Requires Electronic Ballast, White	

- Check compatibility at GELighting.com/LED4pin-compatibility

Updated / New Product

Information provided is subject to change without notice. Please verify all details with GE. All values are design or typical values when measured under laboratory conditions, and GE makes no warranty or guarantee, expressed or implied, that such performance will be obtained under end-use conditions.

* The life rating is based on the hours of operation the lamp will provide before reaching 70% of its original rating (L70)

** Minimum order quantity = 6

★ ENERGY STAR® status: ENERGY STAR® certified. Lamps without a ★ are not ENERGY STAR® certified.

UL 1993 Environmental Requirements for LED LAMPS

Location, damp - Exterior or interior location that is normally or periodically subject to condensation of moisture in, on, or adjacent to, electrical equipment, and includes partially protected locations.

Location, dry - Location not normally subject to dampness, may include a location subject to temporary dampness, i.e., building under construction, provided ventilation is adequate to prevent an accumulation of moisture.

Location, wet - Location in which water or other liquid can drip, splash, or flow on or against electrical equipment.

Notes: 1) Product descriptions ending in "/TP" indicate a carded blister or clamshell package nested in a tray for shelf display. Cards also designed for hook display.

Get more information at
GELighting.com/ThinkLED

LED replacement tubes

High Lumen Biax

Bulb Shape	Base Type	Watts	Order Code	Description	Volts	Case Qty**	MOL (In)	Lumens Initial	CBCP	Initial Color Temp	CRI	Wattage Replacement	*Rated Life L70 (Hrs)	Dimmable	#Location Rating	Additional Information
High Lumen Biax (HLBX)																
HLBX	2G11	17	39073	LED172G11/830/10	#	10	22.3	2150		3000	80		40000	-	Damp	Indoor, White, Instant/PS Ballast
			39074	LED172G11/835/10	#	10	22.3	2150		3500	80		40000	-	Damp	Indoor, White, Instant/PS Ballast
			39075	LED172G11/840/10	#	10	22.3	2200		4000	80		40000	-	Damp	Indoor, White, Instant/PS Ballast
			39076	LED172G11/850/10	#	10	22.3	2200		5000	80		40000	-	Damp	MTO, 1000 Min. Qty., 12 Week Lead Time

- Check compatibility at GELighting.com/LED2G11-compatibility

RS Cans

Bulb Shape	Base Type	Watts	Order Code	Description	Volts	Case Qty**	MOL (In)	Lumens Initial	CBCP	Initial Color Temp	CRI	Wattage Replacement	*Rated Life L70 (Hrs)	Dimmable	ENERGY STAR® Status	#Location Rating	Additional Information
RS Cans																	
	E26	10	95853	LED10RS4/827E26P	120	12	5.88	700		2700	80	65W	50,000	Yes	★	Damp	4" Can, Pigtail Attachment
			95854	LED10RS4/830E26P	120	12	5.88	700		3000	80	65W	50,000	Yes	★	Damp	4" Can, Pigtail Attachment
			35365	LED10RS4/840E26P	120	12	7.5	700		4000	80	65W	50,000	Yes	★	Damp	4" Can, Pigtail Attachment
	GU24		95855	LED10RS4/827GUP	120	12	5.88	700		2700	80	65W	50,000	Yes	★	Damp	4" Can, Pigtail Attachment
			95856	LED10RS4/830GUP	120	12	5.88	700		3000	80	65W	50,000	Yes	★	Damp	4" Can, Pigtail Attachment
	E26		85153	LED10RS6/827E26P	120	12	7.5	700		2700	80	65W	50,000	Yes	★	Damp	6" Can, Pigtail Attachment
			85160	LED10RS6/830E26P	120	12	7.5	700		3000	80	65W	50,000	Yes	★	Damp	6" Can, Pigtail Attachment
			30367	LED10RS6/840E26P	120	12	7.5	700		4000	80	65W	50,000	Yes	★	Damp	6" Can, Pigtail Attachment
	GU24		95851	LED10RS6/827GUP	120	12	7.5	700		2700	80	65W	50,000	Yes	★	Damp	6" Can, Pigtail Attachment
			95852	LED10RS6/830GUP	120	12	7.5	700		3000	80	65W	50,000	Yes	★	Damp	6" Can, Pigtail Attachment
	E26	13	70120	LED13RS6/827E26P	120	12	7.5	1000		2700	80	90W	50,000	Yes	★	Damp	6" Can, Pigtail Attachment
			70122	LED13RS6/830E26P	120	12	7.5	1000		3000	80	90W	50,000	Yes	★	Damp	6" Can, Pigtail Attachment
	GU24		70124	LED13RS6/827GUP	120	12	7.5	1000		2700	80	90W	50,000	Yes	★	Damp	6" Can, Pigtail Attachment
			70127	LED13RS6/830GUP	120	12	7.5	1000		3000	80	90W	50,000	Yes	★	Damp	6" Can, Pigtail Attachment

Updated / New Product

Information provided is subject to change without notice. Please verify all details with GE. All values are design or typical values when measured under laboratory conditions, and GE makes no warranty or guarantee, expressed or implied, that such performance will be obtained under end-use conditions.

* The life rating is based on the hours of operation the lamp will provide before reaching 70% of its original rating (L70)
 ** Minimum order quantity = 6

UL 1993 Environmental Requirements for LED LAMPS
 Location, damp - Exterior or interior location that is normally or periodically subject to condensation of moisture in, on, or adjacent to, electrical equipment, and includes partially protected locations.
 Location, dry - Location not normally subject to dampness, may include a location subject to temporary dampness, i.e., building under construction, provided ventilation is adequate to prevent an accumulation of moisture.
 Location, wet - Location in which water or other liquid can drip, splash, or flow on or against electrical equipment.

Notes: 1) Product descriptions ending in "/TP" indicate a carded blister or clamshell package nested in a tray for shelf display. Cards also designed for hook display.

Get more information at
GELighting.com/ThinkLED

LED replacement lamps

Integrated Plastic Tubes - Type A

Type	Base Type	Watts	Order Code	Description	Volts	Case Qty	MOL (In)	Lumens Initial	Initial Color Temp	CRI	Wattage Replacement	*Rated Life L70 (Hrs)	DLC	UL	#Location Rating	Additional Information
Integrated 4ft LED Plastic Tubes (operates on Instant Start or Program Start Ballast)																
T8	G13	18	31550	LED18ET8/4/830	25	48	2150	3000K	80+		50,000	Yes	Yes	Damp	Instant or PRS Ballast	
	G13	18	93133	LED18ET8/4/835	25	48	2250	3500K	80+		50,000	Yes	Yes	Damp	Instant or PRS Ballast	
	G13	18	93135	LED18ET8/4/840	25	48	2250	4000K	80+		50,000	Yes	Yes	Damp	Instant or PRS Ballast	
	G13	18	93140	LED18ET8/4/850	25	48	2350	5000K	80+		50,000	Yes	Yes	Damp	Instant or PRS Ballast	
	G13	15	62399	LED15ET8/4/830	25	48	1850	3000K	80+		50,000	Yes	Yes	Damp	Instant or PRS Ballast	
	G13	15	62401	LED15ET8/4/835	25	48	1950	3500K	80+		50,000	Yes	Yes	Damp	Instant or PRS Ballast	
	G13	15	62402	LED15ET8/4/840	25	48	1950	4000K	80+		50,000	Yes	Yes	Damp	Instant or PRS Ballast	
	G13	15	62409	LED15ET8/4/850	25	48	2050	5000K	80+		50,000	Yes	Yes	Damp	Instant or PRS Ballast	
	G13	15	62410	LED15ET8/4/865	25	48	1950	6500K	80+		50,000	-	Yes	Damp	Instant or PRS Ballast	
	G13	12	61218	LED12ET8/4/830	25	48	1550	3000K	80+		50,000	Yes	Yes	Damp	Instant or PRS Ballast	
	G13	12	61223	LED12ET8/4/835	25	48	1600	3500K	80+		50,000	Yes	Yes	Damp	Instant or PRS Ballast	
	G13	12	61271	LED12ET8/4/840	25	48	1600	4000K	80+		50,000	Yes	Yes	Damp	Instant or PRS Ballast	
	G13	12	61327	LED12ET8/4/850	25	48	1700	5000K	80+		50,000	Yes	Yes	Damp	Instant or PRS Ballast	
	G13	12	61329	LED12ET8/4/865	25	48	1600	6500K	80+		50,000	-	Yes	Damp	Instant or PRS Ballast	
Integrated 3ft LED Plastic Tubes (operates on Instant Start or Program Start Ballast)																
	G13	12	31554	LED12ET8/3/830	25	36	1350	3000K	80+		50,000	-	Yes	Damp	Instant or PRS Ballast	
	G13	12	26544	LED12ET8/3/835	25	36	1400	3500K	80+		50,000	-	Yes	Damp	Instant or PRS Ballast	
	G13	12	26625	LED12ET8/3/840	25	36	1400	4000K	80+		50,000	-	Yes	Damp	Instant or PRS Ballast	
	G13	12	26627	LED12ET8/3/850	25	36	1500	5000K	80+		50,000	-	Yes	Damp	Instant or PRS Ballast	
Integrated 2ft LED Plastic Tubes (operates on Instant Start or Program Start Ballast)																
	G13	9	31557	LED9ET8/2/830	25	24	1100	3000K	80+		50,000	Yes	Yes	Damp	Instant or PRS Ballast	
	G13	9	26635	LED9ET8/2/835	25	24	1100	3500K	80+		50,000	Yes	Yes	Damp	Instant or PRS Ballast	
	G13	9	26648	LED9ET8/2/840	25	24	1100	4000K	80+		50,000	Yes	Yes	Damp	Instant or PRS Ballast	
	G13	9	26676	LED9ET8/2/850	25	24	1100	5000K	80+		50,000	Yes	Yes	Damp	Instant or PRS Ballast	
Integrated U6 Plastic Tubes																
	G13	13	43120	LED13ET8/U6/830	12	22.5	1800	3000K	80+		50,000	-	Yes	Damp	Instant or PRS Ballast	
	G13	13	43125	LED13ET8/U6/835	12	22.5	1850	3500K	80+		50,000	-	Yes	Damp	Instant or PRS Ballast	
	G13	13	43129	LED13ET8/U6/840	12	22.5	1900	4000K	80+		50,000	-	Yes	Damp	Instant or PRS Ballast	
	G13	13	43130	LED13ET8/U6/850	12	22.5	1900	5000K	80+		50,000	-	Yes	Damp	Instant or PRS Ballast	

Updated / New Product

Information provided is subject to change without notice. Please verify all details with GE. All values are design or typical values when measured under laboratory conditions, and GE makes no warranty or guarantee, expressed or implied, that such performance will be obtained under end-use conditions.

* The life rating is based on the hours of operation the lamp will provide before reaching 70% of its original rating (L70)

** Minimum order quantity = 6

★ ENERGY STAR® status: ENERGY STAR® certified. Lamps without a ★ are not ENERGY STAR® certified.

UL 1993 Environmental Requirements for LED LAMPS

Location, damp - Exterior or interior location that is normally or periodically subject to condensation of moisture in, on, or adjacent to, electrical equipment, and includes partially protected locations.

Location, dry - Location not normally subject to dampness, may include a location subject to temporary dampness, i.e., building under construction, provided ventilation is adequate to prevent an accumulation of moisture.

Location, wet - Location in which water or other liquid can drip, splash, or flow on or against electrical equipment.

Notes: 1) Product descriptions ending in "/TP" indicate a carded blister or clamshell package nested in a tray for shelf display. Cards also designed for hook display.

Get more information at
GELighting.com/ThinkLED

LED replacement tubes

Integrated Glass Tubes - Type A

Type	Base Type	Watts	Order Code	Description	Volts	Case Qty**	MOL (In)	Lumens Initial	Initial Color Temp	CRI	Wattage Replacement	*Rated Life L70 (Hrs)	DLC	UL	#Location Rating	Additional Information
Integrated 4 ft LED Glass Tubes (operates on Instant Start or Program Start Ballast)																
T8	G13	18	35767	LED18ET8/G/4/830	20	48	2200	3000K	80+			50,000	Yes	Yes	Damp	Instant or PRS Ballast
	G13	18	35768	LED18ET8/G/4/835	20	48	2300	3500K	80+			50,000	Yes	Yes	Damp	Instant or PRS Ballast
	G13	18	35769	LED18ET8/G/4/840	20	48	2300	4000K	80+			50,000	Yes	Yes	Damp	Instant or PRS Ballast
	G13	18	35772	LED18ET8/G/4/850	20	48	2400	5000K	80+			50,000	Yes	Yes	Damp	Instant or PRS Ballast
	G13	18	35773	LED18ET8/G/4/865	20	48	2300	6500K	80+			50,000	-	Yes	Damp	Instant or PRS Ballast
	G13	15	35790	LED15ET8/G/4/830	20	48	1900	3000K	80+			50,000	Yes	Yes	Damp	Instant or PRS Ballast
	G13	15	35791	LED15ET8/G/4/835	20	48	2000	3500K	80+			50,000	Yes	Yes	Damp	Instant or PRS Ballast
	G13	15	35793	LED15ET8/G/4/840	20	48	2000	4000K	80+			50,000	Yes	Yes	Damp	Instant or PRS Ballast
	G13	15	35797	LED15ET8/G/4/850	20	48	2100	5000K	80+			50,000	Yes	Yes	Damp	Instant or PRS Ballast
	G13	15	35798	LED15ET8/G/4/865	20	48	2000	6500K	80+			50,000	-	Yes	Damp	Instant or PRS Ballast
	G13	12	43284	LED12ET8/G/4/830	20	48	1600	3000K	80+			50,000	Yes	Yes	Damp	Instant or PRS Ballast
	G13	12	43288	LED12ET8/G/4/835	20	48	1650	3500K	80+			50,000	Yes	Yes	Damp	Instant or PRS Ballast
	G13	12	43291	LED12ET8/G/4/840	20	48	1650	4000K	80+			50,000	Yes	Yes	Damp	Instant or PRS Ballast
	G13	12	43293	LED12ET8/G/4/850	20	48	1750	5000K	80+			50,000	Yes	Yes	Damp	Instant or PRS Ballast
Integrated 4 ft Value LED Glass Tubes (operates on Instant Start or Program Start Ballast)																
T8	G13	15	35896	LED15ET8/835-V6P	6	48	1750	3500K	80+			36,000	-	Yes	Damp	Instant or PRS Ballast
	G13	15	35900	LED15ET8/840-V6P	6	48	1750	4000K	80+			36,000	-	Yes	Damp	Instant or PRS Ballast
	G13	15	35911	LED15ET8/850-V6P	6	48	1800	5000K	80+			36,000	-	Yes	Damp	Instant or PRS Ballast
	G13	15	35913	LED15ET8/865-V6P	6	48	1800	6500K	80+			36,000	-	Yes	Damp	Instant or PRS Ballast
Integrated 3 ft LED Glass Tubes (operates on Instant Start or Program Start Ballast)																
	G13	11	35783	LED11ET8/G/3/830	20	36	1350	3000K	80+			50,000	-	Yes	Damp	Instant or PRS Ballast
	G13	11	35784	LED11ET8/G/3/835	20	36	1400	3500K	80+			50,000	-	Yes	Damp	Instant or PRS Ballast
	G13	11	35788	LED11ET8/G/3/840	20	36	1400	4000K	80+			50,000	-	Yes	Damp	Instant or PRS Ballast
	G13	11	35789	LED11ET8/G/3/850	20	36	1500	5000K	80+			50,000	-	Yes	Damp	Instant or PRS Ballast
Integrated 2 ft LED Glass Tubes (operates on Instant Start or Program Start Ballast)																
	G13	8	35775	LED8ET8/G/2/830	20	24	1100	3000K	80+			50,000	Yes	Yes	Damp	Instant or PRS Ballast
	G13	8	35776	LED8ET8/G/2/835	20	24	1100	3500K	80+			50,000	Yes	Yes	Damp	Instant or PRS Ballast
	G13	8	35778	LED8ET8/G/2/840	20	24	1100	4000K	80+			50,000	Yes	Yes	Damp	Instant or PRS Ballast
	G13	8	35779	LED8ET8/G/2/850	20	24	1100	5000K	80+			50,000	Yes	Yes	Damp	Instant or PRS Ballast

Updated / New Product

Information provided is subject to change without notice. Please verify all details with GE. All values are design or typical values when measured under laboratory conditions, and GE makes no warranty or guarantee, expressed or implied, that such performance will be obtained under end-use conditions.

* The life rating is based on the hours of operation the lamp will provide before reaching 70% of its original rating (L70)

** Minimum order quantity = 6

UL 1993 Environmental Requirements for LED LAMPS

Location, damp - Exterior or interior location that is normally or periodically subject to condensation of moisture in, on, or adjacent to, electrical equipment, and includes partially protected locations.

Location, dry - Location not normally subject to dampness, may include a location subject to temporary dampness, i.e., building under construction, provided ventilation is adequate to prevent an accumulation of moisture.

Location, wet - Location in which water or other liquid can drip, splash, or flow on or against electrical equipment.

Notes: 1) Product descriptions ending in "/TP" indicate a carded blister or clamshell package nested in a tray for shelf display. Cards also designed for hook display.

Get more information at
GELighting.com/ThinkLED

LED replacement tubes

Remote Plastic Tubes - Type C

Type	Base Type	Watts	Order Code	Description	Volts	Case Qty**	MOL (In)	Lumens Initial	Initial Color Temp	CRI	Wattage Replacement	*Rated Life L70 (Hrs)	DLC	UL	#Location Rating	Additional Information
Remote Plastic 4 ft LED Tubes (Operates on Remote Driver)																
T8	G13	18	94381	LED21T8/4/835	10	48	2400	3500K	80+		50,000	Yes	Yes	Damp	Requires Driver	
	G13	18	94382	LED21T8/4/840	10	48	2500	4000K	80+		50,000	Yes	Yes	Damp	Requires Driver	
	G13	18	94383	LED21T8/4/850	10	48	2500	5000K	80+		50,000	Yes	Yes	Damp	Requires Driver	
	G13	18	26059	LED21T8/4/865	10	48	2400	6500K	80+		50,000	-	Yes	Damp	Requires Driver	
	G13	13	38954	LED15T8/4/830	10	48	1700	3000K	80+		50,000	Yes	Yes	Damp	Requires Driver	
	G13	13	38957	LED15T8/4/835	10	48	1800	3500K	80+		50,000	Yes	Yes	Damp	Requires Driver	
	G13	13	38958	LED15T8/4/840	10	48	1800	4000K	80+		50,000	Yes	Yes	Damp	Requires Driver	
	G13	13	38962	LED15T8/4/850	10	48	1800	5000K	80+		50,000	Yes	Yes	Damp	Requires Driver	
	G13	13	38964	LED15T8/4/865	10	48	1800	6500K	80+		50,000	-	Yes	Damp	Requires Driver	
Remote Plastic 3 ft LED Tubes (Operates on Remote Driver)																
G13	16	82343	LED18T8/3/835	10	36	1800	3500K	80+			50,000	-	Yes	Damp	Requires Driver	
G13	16	82345	LED18T8/3/840	10	36	1800	4000K	80+			50,000	-	Yes	Damp	Requires Driver	
G13	16	82346	LED18T8/3/850	10	36	1800	5000K	80+			50,000	-	Yes	Damp	Requires Driver	
Remote Plastic 2 ft LED Tubes (Operates on Remote Driver)																
G13	8	65706	LED9T8/2/835	20	24	1000	3500K	80+			50,000	Yes	Yes	Damp	Requires Driver	
G13	8	65707	LED9T8/2/840	20	24	1100	4000K	80+			50,000	Yes	Yes	Damp	Requires Driver	
G13	8	65711	LED9T8/2/850	20	24	1100	5000K	80+			50,000	Yes	Yes	Damp	Requires Driver	
G13	8	92997	LED9T8/2/865	20	24	1000	6500K	80+			50,000	-	Yes	Damp	Requires Driver	
Remote Plastic LED U Tubes (Operates on Remote Driver)																
G13	12	28084	LED14T8/U/835	15	22.5	1700	3500K	80+			50,000	-	Yes	Damp	Requires Driver	
G13	12	28164	LED14T8/U/840	15	22.5	1700	4000K	80+			50,000	-	Yes	Damp	Requires Driver	

Updated / New Product

Information provided is subject to change without notice. Please verify all details with GE. All values are design or typical values when measured under laboratory conditions, and GE makes no warranty or guarantee, expressed or implied, that such performance will be obtained under end-use conditions.

* The life rating is based on the hours of operation the lamp will provide before reaching 70% of its original rating (L70)

** Minimum order quantity = 6

★ ENERGY STAR® status: ENERGY STAR® certified. Lamps without a ★ are not ENERGY STAR® certified.

UL 1993 Environmental Requirements for LED LAMPS

Location, damp - Exterior or interior location that is normally or periodically subject to condensation of moisture in, on, or adjacent to, electrical equipment, and includes partially protected locations.

Location, dry - Location not normally subject to dampness, may include a location subject to temporary dampness, i.e., building under construction, provided ventilation is adequate to prevent an accumulation of moisture.

Location, wet - Location in which water or other liquid can drip, splash, or flow on or against electrical equipment.

Notes: 1) Product descriptions ending in "/TP" indicate a carded blister or clamshell package nested in a tray for shelf display. Cards also designed for hook display.

Get more information at
GELighting.com/ThinkLED

LED replacement lamps

Remote Glass Tubes - Type C

Type	Base Type	Watts	Order Code	Description	Volts	Case Qty**	MOL (In)	Lumens Initial	Initial Color Temp	CRI	Wattage Replacement	*Rated Life L70 (Hrs)	DLC	UL	#Location Rating	Additional Information
Remote 4ft LED Glass Tubes (Operates on Remote Driver)																
T8	G13	18	62428	LED21T8/G/4/835	10	48	48	2400	3500K	80+		50,000	Yes	Yes	Damp	Requires Driver
	G13	18	62485	LED21T8/G/4/840	10	48	48	2500	4000K	80+		50,000	Yes	Yes	Damp	Requires Driver
	G13	18	62487	LED21T8/G/4/850	10	48	48	2500	5000K	80+		50,000	Yes	Yes	Damp	Requires Driver
	G13	18	62406	LED21T8/G/4/835HL	10	48	48	2750	3500K	80+		50,000	Yes	Yes	Damp	Requires Driver
	G13	18	62407	LED21T8/G/4/840HL	10	48	48	2800	4000K	80+		50,000	Yes	Yes	Damp	Requires Driver
	G13	18	62408	LED21T8/G/4/850HL	10	48	48	2800	5000K	80+		50,000	Yes	Yes	Damp	Requires Driver
	G13	18	91475	LED21T8/G/4/830US	10	48	48	2600	3000K	80+		50,000	Yes	Yes	Damp	Requires Driver - Made in USA
	G13	18	91496	LED21T8/G/4/835US	10	48	48	2600	3500K	80+		50,000	Yes	Yes	Damp	Requires Driver - Made in USA
	G13	18	91497	LED21T8/G/4/840US	10	48	48	2600	4000K	80+		50,000	Yes	Yes	Damp	Requires Driver - Made in USA
	G13	18	91498	LED21T8/G/4/850US	10	48	48	2600	5000K	80+		50,000	Yes	Yes	Damp	Requires Driver - Made in USA
	G13	13	38944	LED15T8/G/4/830	10	48	48	1700	3000K	80+		50,000	Yes	Yes	Damp	Requires Driver
	G13	13	38945	LED15T8/G/4/835	10	48	48	1750	3500K	80+		50,000	Yes	Yes	Damp	Requires Driver
	G13	13	38950	LED15T8/G/4/840	10	48	48	1800	4000K	80+		50,000	Yes	Yes	Damp	Requires Driver
	G13	13	38951	LED15T8/G/4/850	10	48	48	1800	5000K	80+		50,000	Yes	Yes	Damp	Requires Driver
	G13	13	38952	LED15T8/G/4/865	10	48	48	1800	6500K	80+		50,000	-	Yes	Damp	Requires Driver
	G13	10	76194	LED12T8/G/4/830	10	48	48	1550	3000K	80+		50,000	Yes	Yes	Damp	Requires Driver
	G13	10	76264	LED12T8/G/4/835	10	48	48	1600	3500K	80+		50,000	Yes	Yes	Damp	Requires Driver
	G13	10	76265	LED12T8/G/4/840	10	48	48	1650	4000K	80+		50,000	Yes	Yes	Damp	Requires Driver
	G13	10	76271	LED12T8/G/4/850	10	48	48	1650	5000K	80+		50,000	Yes	Yes	Damp	Requires Driver
	G13	10	76278	LED12T8/G/4/865	10	48	48	1650	6500K	80+		50,000	-	Yes	Damp	Requires Driver
Remote 3ft LED Glass Tubes (Operates on Remote Driver)																
	G13	16	38257	LED18T8/G/3/830	10	36	36	1800	3000K	80+		50,000	-	Yes	Damp	Requires Driver
	G13	16	38258	LED18T8/G/3/835	10	36	36	1800	3500K	80+		50,000	-	Yes	Damp	Requires Driver
	G13	16	38260	LED18T8/G/3/840	10	36	36	1900	4000K	80+		50,000	-	Yes	Damp	Requires Driver
	G13	16	38261	LED18T8/G/3/850	10	36	36	1900	5000K	80+		50,000	-	Yes	Damp	Requires Driver
Remote 2ft LED Glass Tubes (Operates on Remote Driver)																
	G13	8	38933	LED9T8/G/2/830	20	24	24	1000	3000K	80+		50,000	Yes	Yes	Damp	Requires Driver
	G13	8	38935	LED9T8/G/2/835	20	24	24	1000	3500K	80+		50,000	Yes	Yes	Damp	Requires Driver
	G13	8	38936	LED9T8/G/2/840	20	24	24	1100	4000K	80+		50,000	Yes	Yes	Damp	Requires Driver
	G13	8	38939	LED9T8/G/2/850	20	24	24	1100	5000K	80+		50,000	Yes	Yes	Damp	Requires Driver
	G13	8	38943	LED9T8/G/2/865	20	24	24	1000	6500K	80+		50,000	-	Yes	Damp	Requires Driver
Remote 8ft LED Glass Tubes (Operates on Remote Driver)																
	Fa8	30	62326	LED36T8/G/8/830	20	96	96	4200	3000K	80+		50,000	-	Yes	Damp	Requires Driver - Made in USA
	Fa8	30	62327	LED36T8/G/8/835	20	96	96	4400	3500K	80+		50,000	-	Yes	Damp	Requires Driver - Made in USA
	Fa8	30	62329	LED36T8/G/8/840	20	96	96	4400	4000K	80+		50,000	-	Yes	Damp	Requires Driver - Made in USA
	Fa8	30	62349	LED36T8/G/8/850	20	96	96	4400	5000K	80+		50,000	-	Yes	Damp	Requires Driver - Made in USA
Remote Glass U6 Tubes (Operates on Remote Driver)																
	G13	13	43131	LED15T8/G/U6/830	12	22.5	22.5	1700	3000K	80+		50,000	-	Yes	Damp	Requires Driver
	G13	13	43135	LED15T8/G/U6/835	12	22.5	22.5	1800	3500K	80+		50,000	-	Yes	Damp	Requires Driver
	G13	13	43143	LED15T8/G/U6/840	12	22.5	22.5	1800	4000K	80+		50,000	-	Yes	Damp	Requires Driver
	G13	13	43145	LED15T8/G/U6/850	12	22.5	22.5	1800	5000K	80+		50,000	-	Yes	Damp	Requires Driver
Remote 2ft LED Glass T5 Tubes (Operates on Remote Driver)																
	G5	13	76150	LED15T5/G/2/830	20	24	24	1800	3000K	80+		50,000	-	Yes	Damp	Requires Driver
	G5	13	76164	LED15T5/G/2/835	20	24	24	1850	3500K	80+		50,000	-	Yes	Damp	Requires Driver
	G5	13	76129	LED15T5/G/2/840	20	24	24	1900	4000K	80+		50,000	-	Yes	Damp	Requires Driver
	G5	13	76167	LED15T5/G/2/850	20	24	24	1900	5000K	80+		50,000	-	Yes	Damp	Requires Driver
	G5	13	76192	LED15T5/G/2/865	20	24	24	1900	6500K	80+		50,000	-	Yes	Damp	Requires Driver
Remote 4ft LED Glass T5 Tube (Operates on Remote Driver)																
	G5	31	91973	LED36T5/G/4/830	20	46	46	4100	3000K	80+		50,000	-	Yes	Damp	Requires Driver
	G5	31	91976	LED36T5/G/4/835	20	46	46	4200	3500K	80+		50,000	-	Yes	Damp	Requires Driver
	G5	31	91977	LED36T5/G/4/840	20	46	46	4400	4000K	80+		50,000	-	Yes	Damp	Requires Driver
	G5	31	91997	LED36T5/G/4/850	20	46	46	4500	5000K	80+		50,000	-	Yes	Damp	Requires Driver
	G5	31	92006	LED36T5/G/4/865	20	46	46	4500	6500K	80+		50,000	-	Yes	Damp	Requires Driver

Updated / New Product

Information provided is subject to change without notice. Please verify all details with GE. All values are design or typical values when measured under laboratory conditions, and GE makes no warranty or guarantee, expressed or implied, that such performance will be obtained under end-use conditions.

* The life rating is based on the hours of operation the lamp will provide before reaching 70% of its original rating (L70)

** Minimum order quantity = 6

★ ENERGY STAR® status: ENERGY STAR® certified. Lamps without a ★ are not ENERGY STAR® certified.

UL 1993 Environmental Requirements for LED LAMPS

Location, damp - Exterior or interior location that is normally or periodically subject to condensation of moisture in, on, or adjacent to, electrical equipment, and includes partially protected locations.

Location, dry - Location not normally subject to dampness, may include a location subject to temporary dampness, i.e., building under construction, provided ventilation is adequate to prevent an accumulation of moisture.

Location, wet - Location in which water or other liquid can drip, splash, or flow on or against electrical equipment.

Notes: 1) Product descriptions ending in "/7P" indicate a carded blister or clamshell package nested in a tray for shelf display. Cards also designed for hook display.

Get more information at
GELighting.com/ThinkLED

LED replacement tubes

Remote Drivers

Type	Base Type	Watts	Order Code	Description	Volts	Case Qty**	Output Current (A)	Frequency	Eff	Output	Output Voltage	Temp (Min)	Temp (Max)	Dimmable	Additional Information
Lightech Drivers - Non-Dimming															
	18	93100	LED9T8/DR/UN/2L	120-277V	10	0.27x2	50/60 Hz	>.9	DC	26-34V	-4 F	113 F	-	Maximum 2 Tubes (non potted)	
	24	76289	LED12T8/DR/2L	120-277V	10	0.21x2	50/60 Hz	>.9	DC	26-34V	-4 F	113 F	-	Maximum 2 Tubes	
	30	38970	LED15T8/DR/UN/2L	120-277V	10	0.44x2	50/60 Hz	>.9	DC	26-34V	-4 F	113 F	-	Maximum 2 Tubes (non potted)	
	36	82347	LED18T8/DR/UN/2L	120-277V	10	0.53x2	50/60 Hz	>.9	DC	26-34V	-4 F	113 F	-	Maximum 2 Tubes (non potted)	
	21	94384	LED21T8/DR/1L	120-277V	10	0.62	50/60 Hz	>.9	DC	26-34V	-4 F	113 F	-	Maximum 1 Tube	
	42	94385	LED21T8/DR/2L	120-277V	10	0.62x2	50/60 Hz	>.9	DC	26-34V	-4 F	113 F	-	Maximum 2 Tubes	
Lightech Drivers - Dimming															
	24	76290	LED12T8/DR/D2L	120-277V	10	0.21x2	50/60 Hz	>.9	DC	26-34V	-4 F	113 F	Yes	Maximum 2 Tubes	
	48	76318	LED12T8/DR/D4L	120-277V	10	0.21x4	50/60 Hz	>.9	DC	26-34V	-4 F	113 F	Yes	Maximum 4 Tubes	
	42	28174	LED14/DR/D3L	120-277V	10	0.43x3	50/60 Hz	>.9	DC	26-34V	-4 F	113 F	Yes	Maximum 3 Tubes	
	30	38974	LED15T8/DR/D2L	120-277V	10	0.44x2	50/60 Hz	>.9	DC	26-34V	-4 F	113 F	Yes	Maximum 2 Tubes	
	60	38975	LED15T8/DR/D4L	120-277V	10	0.44x4	50/60 Hz	>.9	DC	26-34V	-4 F	113 F	Yes	Maximum 4 Tubes	
	36	88141	LED18T8/DR/D2L	120-277V	10	0.53x2	50/60 Hz	>.9	DC	26-34V	-4 F	113 F	Yes	Maximum 2 Tubes	
	72	88139	LED18T8/DR/D4L	120-277V	10	0.53x4	50/60 Hz	>.9	DC	26-34V	-4 F	113 F	Yes	Maximum 4 Tubes	
	42	60041	LED21T8/DR/D2L	120-277V	10	0.62x2	50/60 Hz	>.9	DC	26-34V	-4 F	113 F	Yes	Maximum 2 Tubes	
	84	62030	LED21T8/DR/D4L	120-277V	10	0.62x4	50/60 Hz	>.9	DC	26-34V	-4 F	113 F	Yes	Maximum 4 Tubes	
	45	34016	LED21T8/DR/VLC2L	120-277V	10	0.62x2	50/60 Hz	>.9	DC	26-34V	-4 F	113 F	Yes	Maximum 2 Tubes	
	72	63126	LED36T8/DR/D2L	120-277V	10	1.06x2	50/60 Hz	>.9	DC	26-34V	-4 F	113 F	Yes	Maximum 2 Tubes	
	144	92013	LED36T8/DR/D4L	120-277V	10	1.06x4	50/60 Hz	>.9	DC	26-34V	-4 F	113F	Yes	Maximum 4 Tube	

Updated / New Product

Information provided is subject to change without notice. Please verify all details with GE. All values are design or typical values when measured under laboratory conditions, and GE makes no warranty or guarantee, expressed or implied, that such performance will be obtained under end-use conditions.

* The life rating is based on the hours of operation the lamp will provide before reaching 70% of its original rating (L70)

** Minimum order quantity = 6

★ ENERGY STAR® status: ENERGY STAR® certified. Lamps without a ★ are not ENERGY STAR® certified.

UL 1993 Environmental Requirements for LED LAMPS

Location, damp - Exterior or interior location that is normally or periodically subject to condensation of moisture in, on, or adjacent to, electrical equipment, and includes partially protected locations.

Location, dry - Location not normally subject to dampness, may include a location subject to temporary dampness, i.e., building under construction, provided ventilation is adequate to prevent an accumulation of moisture.

Location, wet - Location in which water or other liquid can drip, splash, or flow on or against electrical equipment.

Notes: 1) Product descriptions ending in "/TP" indicate a carded blister or clamshell package nested in a tray for shelf display. Cards also designed for hook display.

Get more information at
GELighting.com/ThinkLED

Updated / New Product

Information provided is subject to change without notice. Please verify all details with GE. All values are design or typical values when measured under laboratory conditions, and GE makes no warranty or guarantee, expressed or implied, that such performance will be obtained under end-use conditions.

* The life rating is based on the hours of operation the lamp will provide before reaching 70% of its original rating (L70)

** Minimum order quantity = 6

★ ENERGY STAR® status: ENERGY STAR® certified. Lamps without a ★ are not ENERGY STAR® certified.

UL 1993 Environmental Requirements for LED LAMPS

Location, damp - Exterior or interior location that is normally or periodically subject to condensation of moisture in, on, or adjacent to, electrical equipment, and includes partially protected locations.

Location, dry - Location not normally subject to dampness, may include a location subject to temporary dampness, i.e., building under construction, provided ventilation is adequate to prevent an accumulation of moisture.

Location, wet - Location in which water or other liquid can drip, splash, or flow on or against electrical equipment.

Notes: 1) Product descriptions ending in "/TP" indicate a carded blister or clamshell package nested in a tray for shelf display. Cards also designed for hook display.

Get more information at
GELighting.com/ThinkLED

Awaken like never before the moment you turn on GE's LED replacement lamp.

Light influences people's emotions, how they view their space and their world, and how they start and end their day. GE understands this and wants to help transform your stores, buildings or facilities, while ensuring your upfront investment is paid back as quickly as possible.

If you're inspired to enhance your space — with substantial savings — call your GE Lighting representative.

To experience what we've done for our existing customers, see case studies, videos and image galleries at gelighting.com/ThinkLED



Product is compliant with material restriction requirements of RoHS

ENERGY STAR® is a registered U.S. mark



www.gelighting.com

GE and the GE Monogram are trademarks of the General Electric Company. All other trademarks are the property of their respective owners. Information provided is subject to change without notice. All values are design or typical values when measured under laboratory conditions. GE Lighting and GE Lighting Solutions, LLC are businesses of the General Electric Company. © 2016 GE.

78945 (Rev 12/09/2016)